



Konecranes Investor Presentation

April 2025

KONECRANES

Important Notice

The following applies to this presentation, the oral presentation of the information in this presentation by Konecranes Abp (the “Company” or “Konecranes”) or any person on behalf of the Company, and any question-and-answer session that follows the oral presentation (collectively, the “Information”). In accessing the Information, you agree to be bound by the following terms and conditions.

This presentation does not constitute an offer of or an invitation by or on behalf of, Konecranes, or any other person, to purchase any securities.

The Information is not directed to, or intended for distribution to or use by, any person or entity that is a citizen or resident of, or located in, any locality, state, country or other jurisdiction where such distribution or use would be contrary to law or regulation or which would require any registration or licensing within such jurisdiction.

The Information contains forward-looking statements. All statements other than statements of historical fact included in the Information are forward-looking statements. Forward-looking statements give the Company’s current expectations and projections relating to its financial condition, results of operations, plans, objectives, future performance and business. These statements may include, without limitation, any statements preceded by, followed by or including words such as “target,” “believe,” “expect,” “aim,” “intend,” “may,” “anticipate,” “estimate,” “plan,” “project,” “will,” “can have,” “likely,” “should,” “would,” “could” and other words and terms of similar meaning or the negative thereof. Such forward-looking statements involve known and unknown risks, uncertainties and other important factors beyond the Company’s control that could cause the Company’s actual results, performance or achievements to be materially different from the expected results, performance or achievements expressed or implied by such forward-looking statements. Such forward-looking statements are based on numerous assumptions regarding the Company’s present and future business strategies and the environment in which it will operate in the future.

The Information, including but not limited to forward-looking statements, applies only as of the date of this document and is not intended to give any assurances as to future results. Market data used in the Information not attributed to a specific source are estimates of the Company and have not been independently verified.

Agenda

1. Konecranes in brief
2. Updated strategy & financial targets
3. Key financials development
4. Konecranes as an investment
5. Business Area overviews
6. Appendix
7. Latest quarterly result presentation



1. Konecranes in brief



Shaping next generation material handling for a smarter, safer and better world

<p>Nasdaq Helsinki</p> <p>KCR</p> <p>since 1996</p>	<p>Headquartered in</p> <p>Hyvinkää</p> <p>Finland</p>	<p>Active in around</p> <p>50</p> <p>countries</p>	<p>Approximately</p> <p>16,700</p> <p>employees, Q1/25</p>
<p>Orders received</p> <p>3,999.6</p> <p>MEUR, 2024</p>	<p>Net sales</p> <p>4,227.0</p> <p>MEUR, 2024</p>	<p>Comparable EBITA</p> <p>13.1%</p> <p>margin, 2024</p>	<p>Order book</p> <p>2,888.4</p> <p>MEUR, 2024</p>



Two main customer segments, extensive service coverage and a truly global presence

Sales by Business Area 2024

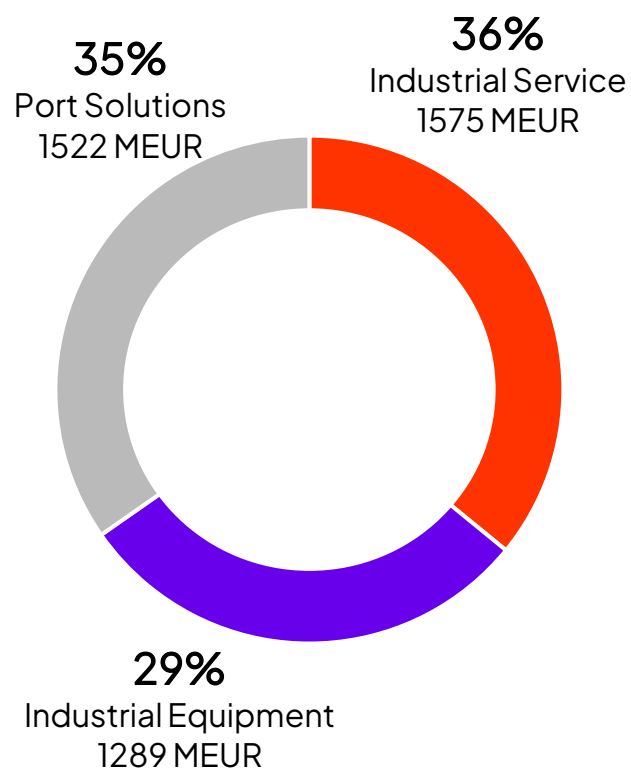

Sales by offering type, 2024

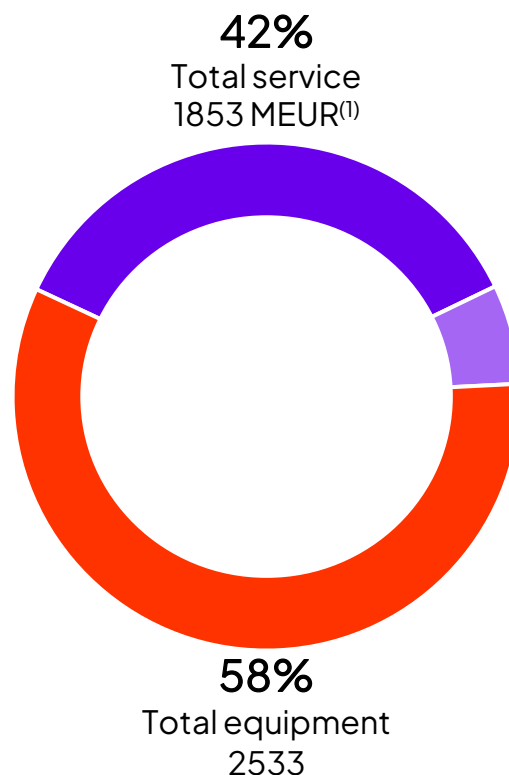

Sales by region, 2024

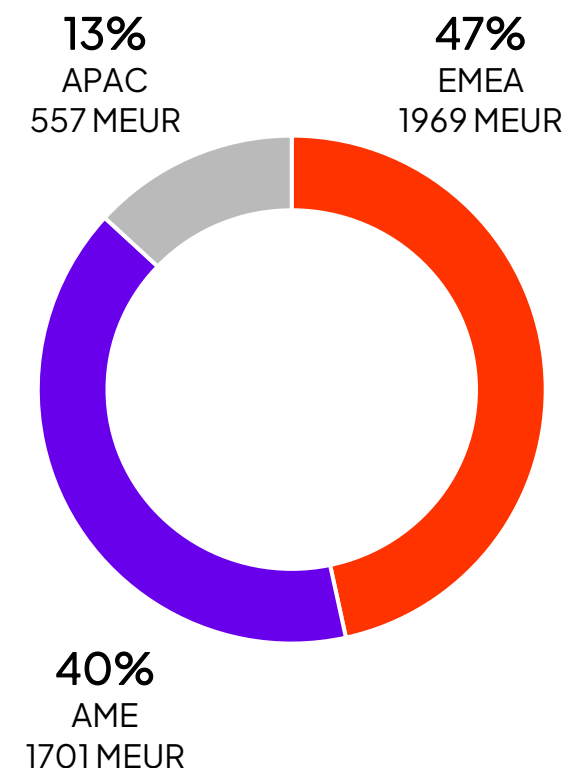

Note (1): Total service includes Service and Port Solutions' service sales of 278.2 MEUR

Note (2): Total equipment includes Industrial Equipment and Port Solutions excluding Port Solutions' service sales of 278.2 MEUR

An industry and technology leader in material handling solutions



Industrial Service

- Specialized maintenance services and spare parts for all types and makes of industrial cranes and hoists
- Unparalleled global service network



Industrial Equipment

- Extensive range of industrial cranes, from components and light duty applications to demanding process solutions
- Technology leadership and leading market position



Port Solutions

- Provides equipment, solutions and service for the container handling industry and ports
- One of the leading global suppliers

We have a solid platform with leading market positions to build on

Business Area



Industrial Service

Net sales
1,574.7
MEUR, 2024

Personnel
7,963
end of Q1 2025

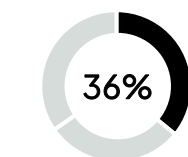

Share of Group's
net sales (2024)

Market & position

~15 BEUR
addressable
core market

Thousands
of participants



Offering

- Inspections & preventive maintenance
- Predictive maintenance & remote monitoring
- Corrective maintenance & retrofits
- Consultation services
- Modernization services
- New equipment & spare parts



Industrial Equipment

Net sales
1,289.3
MEUR, 2024

Personnel
5,214
end of Q1 2025

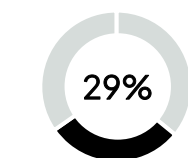

Share of Group's
net sales (2024)

~10 BEUR
addressable
core market

Thousands
of participants



- Hoists and components (electric wire rope hoists, electric chain hoists, Core of Lifting)
- Standard cranes (built from standardized modules, largely comprise overhead cranes)
- Process cranes (application-specific cranes tailored to a specific customer need)



Port Solutions

Net sales
1,521.7
MEUR, 2024

Personnel
3,392
end of Q1 2025

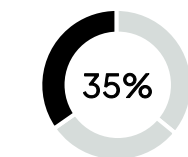

Share of Group's
net sales (2024)

~15-20 BEUR
addressable
core market

Hundreds
of participants

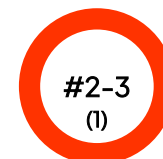

- Quayside cranes (STS, MHC)
- Container yard, intermodal & horizontal transport equipment (RTG, RMG, ARTG, ARMG/ASC, SC, AGV)
- Lift trucks (RS, FLT, LCH/ECH)
- Software solutions (TOS, ECS)
- Service, spare parts, retrofits, modernizations

Note (1): Market position estimate varies depending on Business Unit

Our broad customer base provides both stability and growth opportunities

Orders by customer segments, 2024

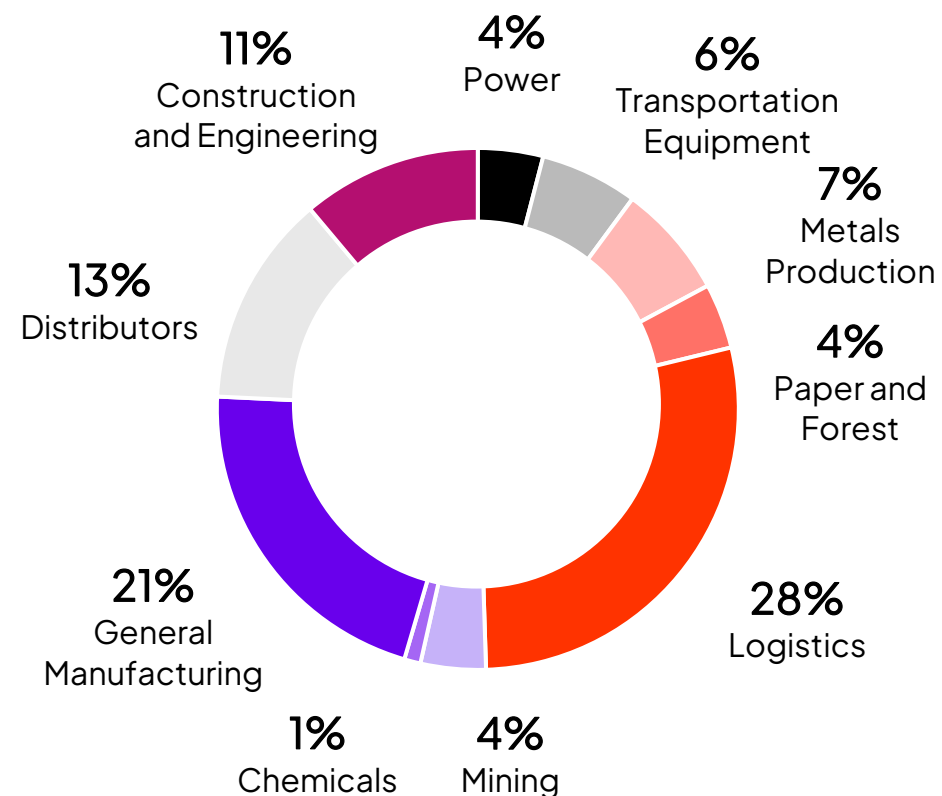

Container handling



General manufacturing



Metals production



Paper and forest



Automotive



Mining



Power & Nuclear

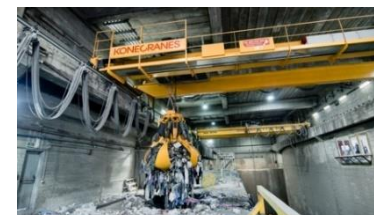

Waste-to-energy



Petroleum and gas

More than 100 years of growth both organically and through strategic acquisitions

<p>Manufacturing starts in Helsinki 1910s</p> 	<p>Expanding to Hyvinkää 1940s</p>	 <p>Establishing a service strategy 1960s</p>	 <p>Visionary leadership and expansion 1980s</p>	<p>Global expansion and lift trucks 2000s</p>	<p>Unveiling of Konecranes' refreshed purpose, ambition and brand 2023-2024</p>
 <p>1930s Developing electric hoists</p>	 <p>1950s War reparations and the start of harbor cranes production</p>	 <p>1970s Crane business pioneer</p>	 <p>1990s An independent company</p>	 <p>2017 Significant growth via the acquisition of the MHPS business</p>	

Around 16,700 employees and production facilities located in the Americas, EMEA and APAC

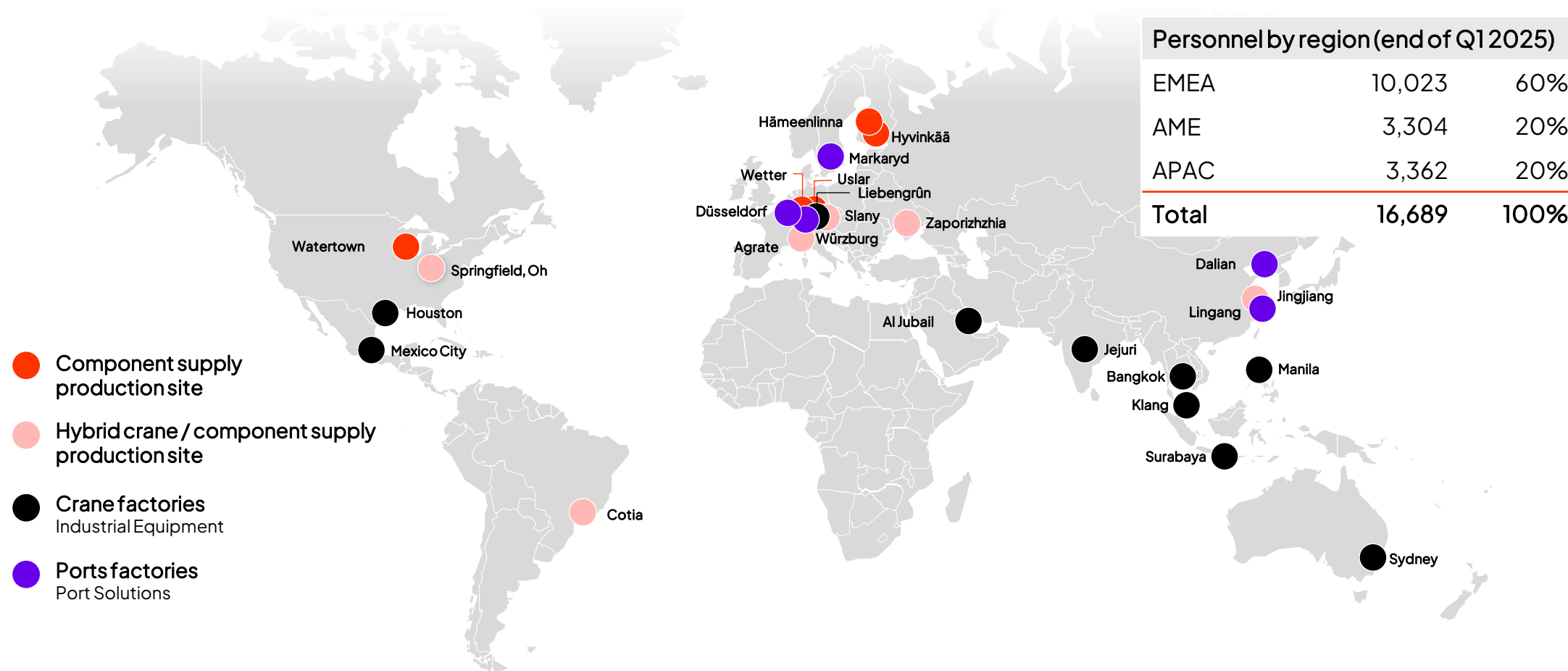

- Component supply production site
- Hybrid crane / component supply production site
- Crane factories
Industrial Equipment
- Ports factories
Port Solutions

Konecranes has identified the following megatrends that shape its markets and provide business opportunities

Sustainability

Sustainability has become **the norm** in business, the focus widening to managing the **whole value chain's impact** on social and environmental aspects

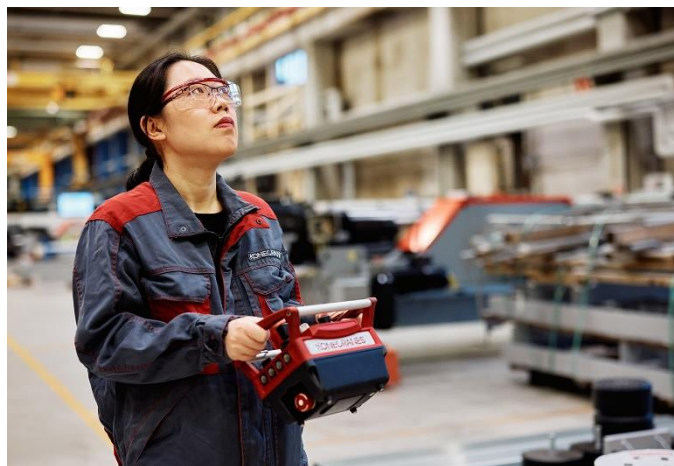

We enable a **decarbonized, circular and safer world** by embedding sustainability across our business and supporting our customers in achieving their targets.

Digitalization and automation

Productivity and seamless operations, enabled by **digitalization and automation**, are a higher priority for companies

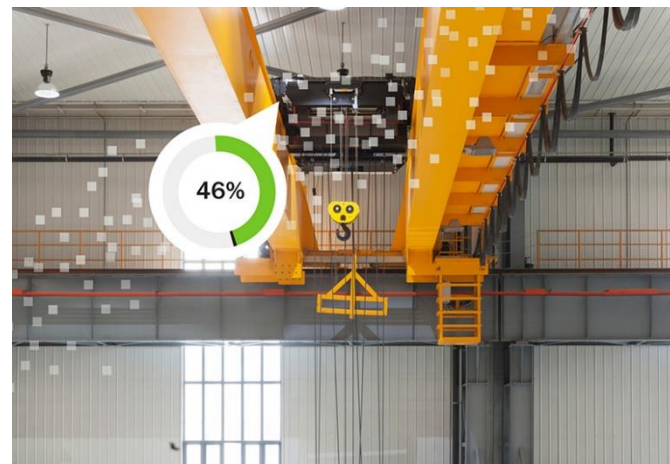

We provide **automated, intelligent** and more complete material handling **solutions** that boost our customers' **productivity**.

Geopolitics and macroeconomics

Geopolitical issues **change** the dynamics in the **global flow of goods and information**, and macroeconomic changes cause overall **economic uncertainty**

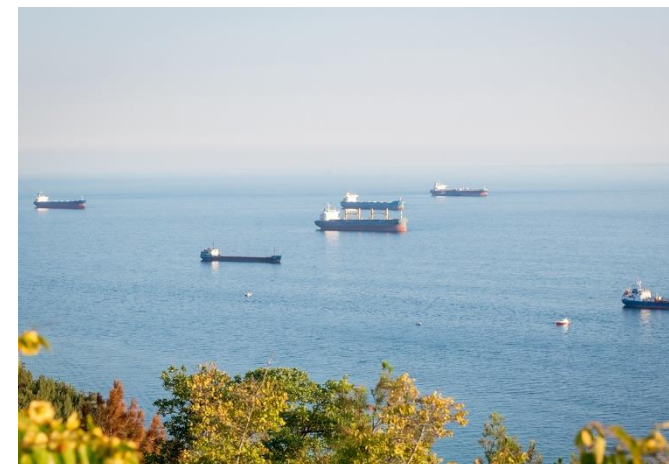

We contribute to **improving data management** and the **resilience** of overall operations and supply networks.

We harness the advantages of our purpose-built componentry, technology innovation and digitalization

- Core of Lifting comprises purpose-built, integrated package of gearbox, motor, control system and connectivity, made specifically for cranes and lifting motion
- Designing and creating the core in-house provides cranes a longer lifetime, optimized performance and cost, increased safety and productivity
- Same unified digital and physical componentry across the entire portfolio enables effective customer engagement throughout the world
- Embedded sensors and software provide real-time data to customers and enable process optimization and predictive maintenance

2,000,000

Motors
since 1933

500,000

Inverter based
control systems
since 1993

49,000

Connected cranes
in 140 countries

2,000

Active and
pending patents

4,500+

Service
technicians



Konecranes' sustainability commitments



We deliver safe and secure material handling solutions

- Providing solutions for safe, uninterrupted and secure material handling
- Ensuring uncompromised safety in our own operations and supply chain



We enable a decarbonized and circular world

- Supporting our customers in reaching their low-carbon targets with our offering
- Maximizing lifecycle value and eliminating waste with circular solutions throughout the whole value chain
- Working to decarbonize our own operations



We create fair, inclusive, diverse and engaging working environment

- Supporting human rights in our value chain
- Ensuring a fair and engaging workplace
- Representing the multicultural communities where we operate



We expect high ethical standards of ourselves and our business partners

- Embedding sustainability, compliance and ethical requirements in our business processes
- Following strong governance on sustainability, compliance and ethics

We have ambitious climate targets and have made great progress towards them

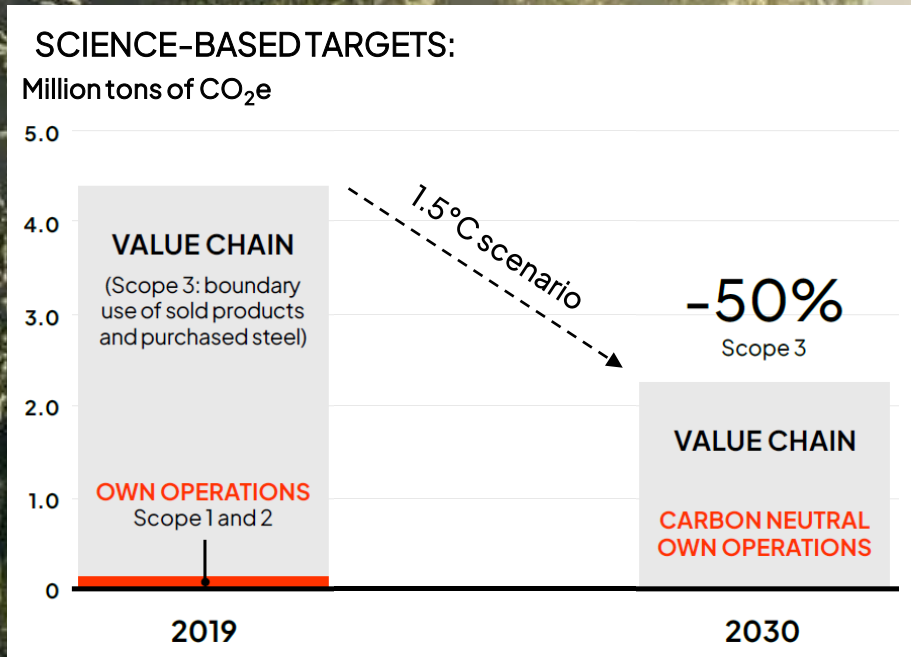

- PROGRESS:**
- Own operations:
- 50% absolute GHG emission reduction⁽¹⁾ by 2030
 - Progress: Target achieved in 2022 (56% reduction in 2019-2024)
 - New, more ambitious target set: Carbon neutral own operations by 2030
- Value chain:
- 50% absolute GHG emissions reduction by 2030⁽¹⁾, encompassing use of sold products and steel purchases⁽²⁾
 - Progress: 12% reduction in 2019-2024

- FOCUS OF PATHWAY ACTIVITIES:**
- Introducing new technological innovations to reduce dependency on fossil fuels
 - Applying smart product design focusing on energy efficiency, durability and maintainability
 - Optimizing material flows with automation and digital solutions
 - Purchasing steel from suppliers with minimum emissions
 - Investing in renewable electricity and energy efficiency in own operations

Our science-based climate targets have been validated by SBTi as being in line with the ambition to limit global warming to 1.5°C.
1) From 2019 base year. 2) The Scope 3 target covers more than 70% of the value chain emissions.

Our sustainability work has been recognized with leadership ratings

Sustainability ratings



Committed to UN SDGs ⁽¹⁾



Selected highlights in 2024:

We deliver safe and secure material handling solutions

- Konecranes received IEC 62443 cybersecurity certification for its product development process, covering RTGs, Process Cranes and Light Lifting products.

We create a fair, inclusive diverse and engaging working environment

- Konecranes paid an adequate wage to all employees, committed to meeting living wage requirements and started to close the gaps. Living wage is higher than the adequate wage in several locations.
- Konecranes measured an 83 percent inclusion index in 2024, indicating a strong feeling of inclusion among our employees.

We expect high ethical standards of ourselves and our business partners

- Konecranes rolled out an updated Supplier Code of Conduct and supplier selection approach was changed from spend-based to risk-based.

Note (1): Konecranes is a signatory member of the UN Global Compact since 2010.

The use by Konecranes of any MSCI ESG research Llc or its affiliates ("MSCI") data, and the use of MSCI logos, trademarks, service marks or index names herein, do not constitute a sponsorship, endorsement, recommendation, or promotion of Konecranes by MSCI. MSCI services and data are the property of MSCI or its information providers, and are provided 'as-is' and without warranty. MSCI names and logos are trademarks or service marks of MSCI.

We have raised our ambition and aim at carbon neutral own operations by 2030

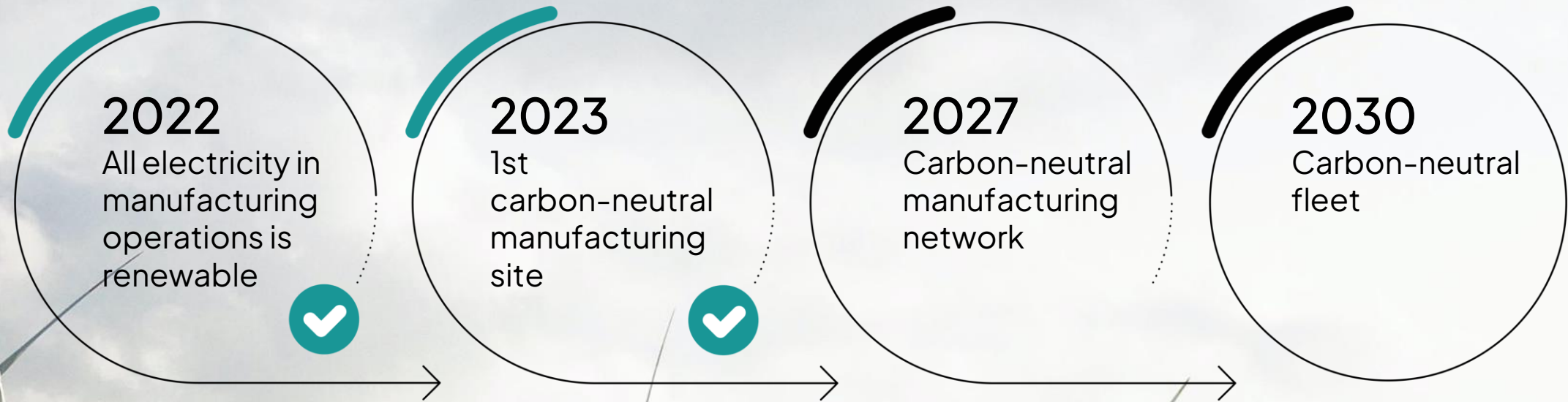

This is Konecranes

Our Purpose

Shaping next generation material handling a for smarter, safer, and better world

Our Ambition

The world leader in material handling solutions, creating value for everyone

Our strategic enablers

Deepening
customer
focus

Accelerating
efficiency

Scaling
technology
innovation

Advancing
responsible
business

Enhancing
our winning
culture

Our Values

Putting customers first

Doing the right thing

Driving for better

Winning together

Our Brand Promise

KONECRANES Moves what matters.

2. Updated strategy & financial targets



Material handling market offers possibility to capture growth

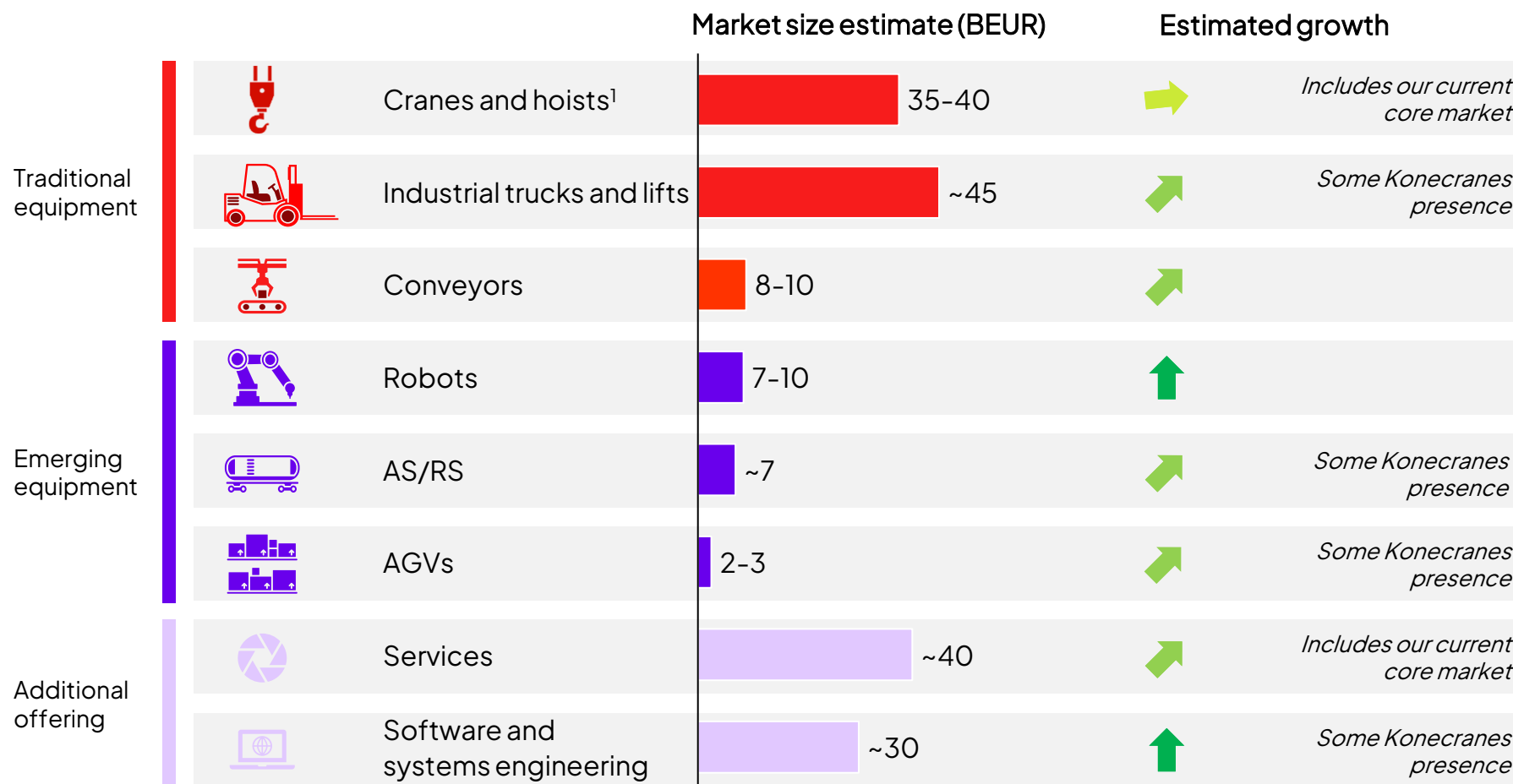

Our focus is on our core businesses...

... at the same time, adjacent material handling areas offer the possibility to capture growth and to fulfil customers' broader material handling needs.

Notes: 1) Cranes and hoists category also includes other cranes and hoists in addition to KC offering
Source: internal analysis

We have a clear strategy to execute in all our Business Segments

Deliver Industrial Service growth



- Renewed Service Program: segmented offering driving agreement base expansion
- Enhanced customer experience
- Commercial and operational excellence
- Equivalent parts for third party equipment
- Data driven sales
- Bolt-on acquisitions

Improve Industrial Equipment profitability



- Simplification of go-to market model
- Renewed and standardized offering
- Platform harmonization
- Operational excellence
- Optimized portfolio
- Stabilization and fixing profitability for Process Cranes

Generate profitable growth in Port Solutions



- Focus on core offering with best growth opportunity
- Growing Port Services
- Capturing automation opportunities
- Operational excellence
- Project management excellence
- Launching sustainable offering

We focus on:

- Profitable and high growth offerings and geographies
- Leveraging technology leadership through automated and digital solutions
- Markets and segments that appreciate the added value of our offering
- Pricing, cost management and internal efficiency
- Operating model with clear authorization and accountability

Our focus is on profitability before embarking on growth

We will manage our businesses by clear mandates for their operations.
Depending on the stage of development, the mandates are either for Stability, Profitability or Growth.

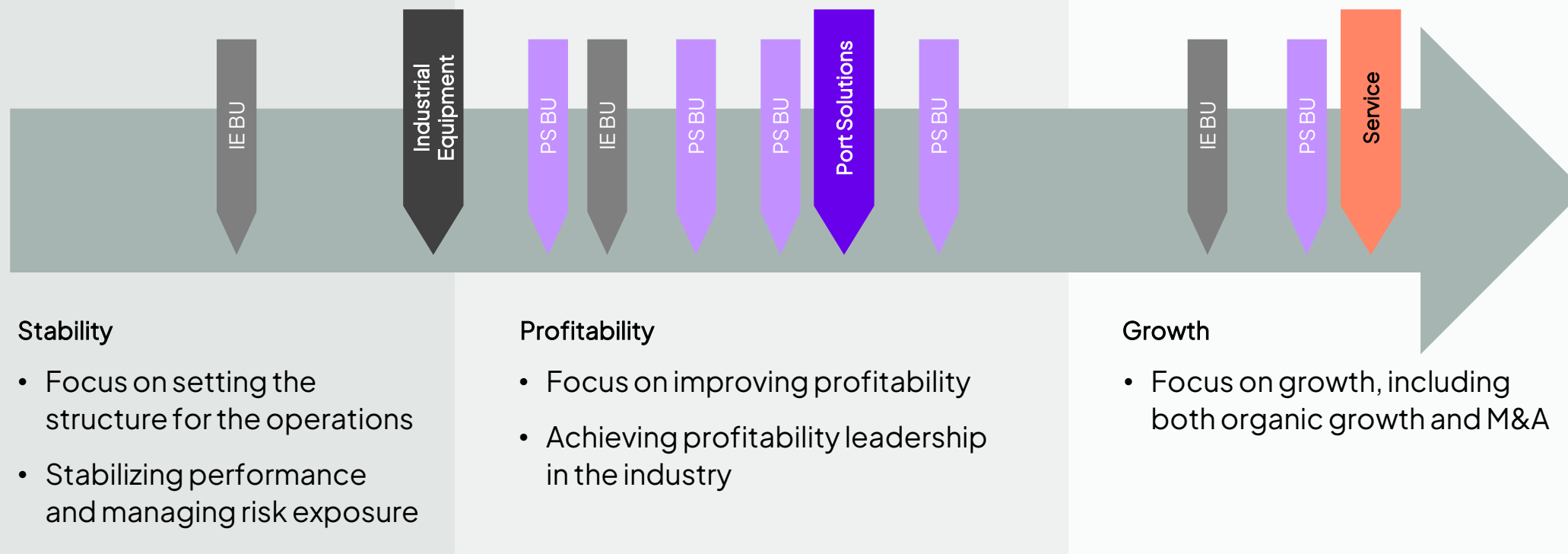

Portfolio management will play an even more important role going forward and we will not shy away from fixing, growing or exiting businesses.

Our Ambition is to become the world leader in material handling solutions creating value for everyone

Financial targets:

- Sales growth faster than the market¹
- Comparable EBITA margin of 12-15%² as soon as possible, but no later than in 2027

Dividend policy:

To pay a stable to increasing dividend per share, over the cycle

¹nominal world GDP growth, IMF World Economic Outlook

²profitability range, depending on the cycle

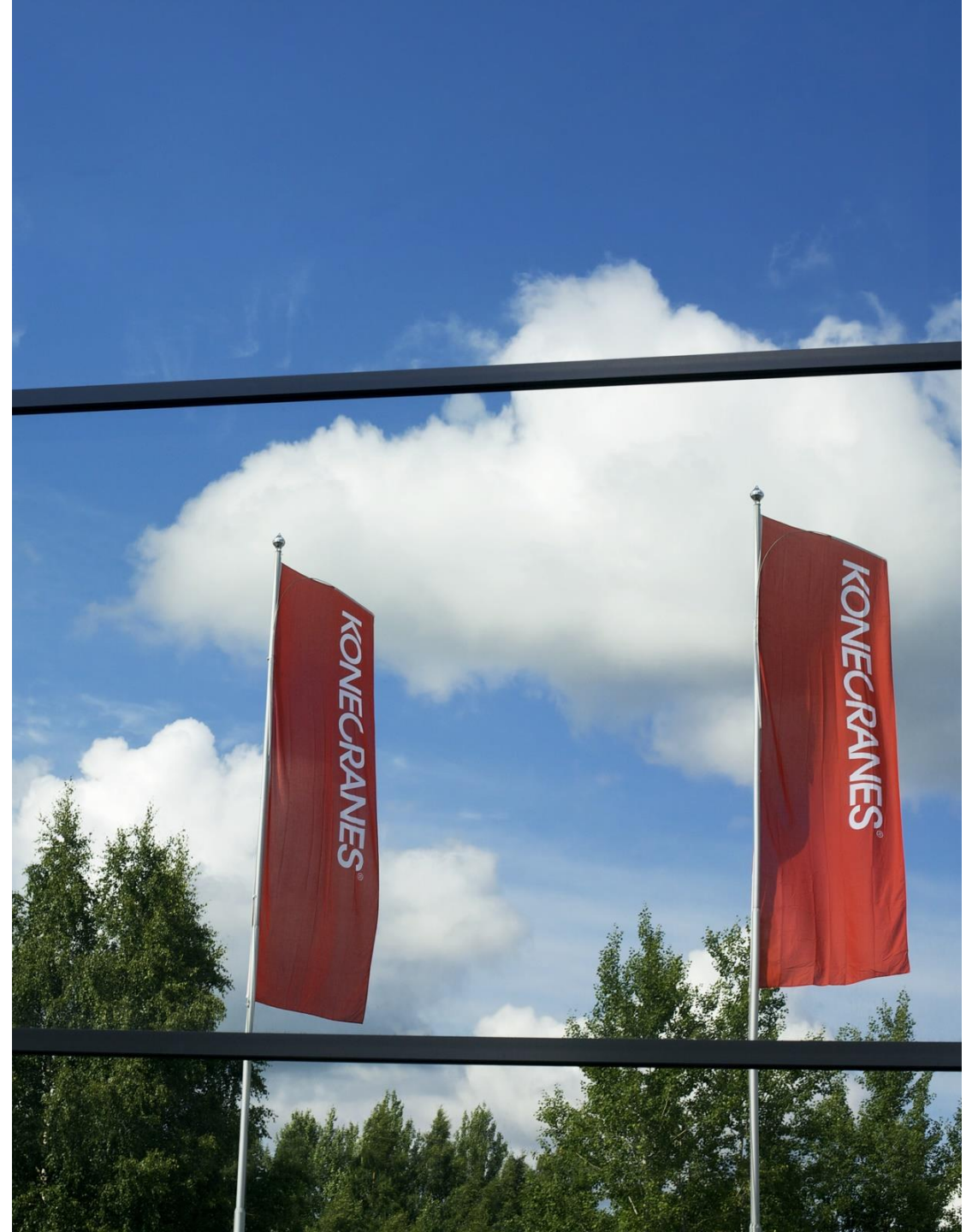

Financial targets

Sales growth faster than the market¹

12-15% comparable EBITA margin²



Comparable EBITA margin target to be reached as soon as possible, but no later than in 2027

¹nominal world GDP growth, IMF World Economic Outlook

²profitability range, depending on the cycle

We pay a stable to increasing dividend to our shareholders

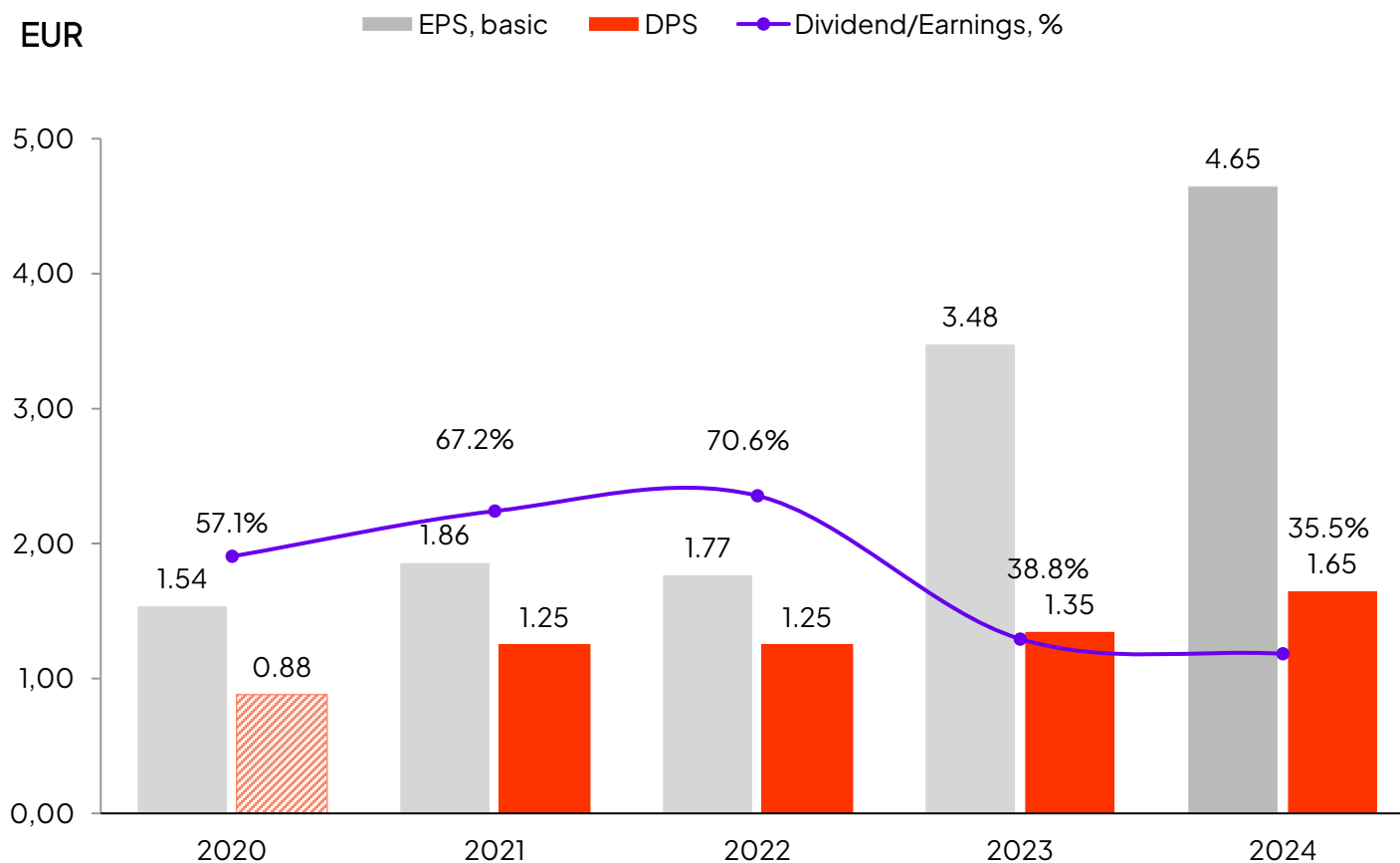

Note (1): For 2020, the dividend of EUR 0.88 per share was in accordance with the Combination Agreement, the planned merger with Cargotec was cancelled in March 2022

Strategic Enablers driving our business forward towards our Ambition and Financial Targets

Deepening customer focus

Accelerating efficiency

Scaling technology innovation

Advancing responsible business

Enhancing our winning culture

Operating model with clear authorization and accountability

We are embedding a winning attitude and growth mindset

- Engaging culture and values
- Competitive mindset
- Deliver what we promise
- Sense of urgency
- Ease of doing business with
- Open, proactive communication
- Performance management
- Continuous improvement



Shaping next generation material handling for a smarter, safer and better world

We have a strong platform to build on and a clear plan to execute:

We have...

- ✓ Great people
- ✓ A leading position in services and equipment
- ✓ A broad customer base
- ✓ An unrivalled global service network
- ✓ Technology leadership
- ✓ Plenty of market opportunities
- ✓ An inspirational Purpose and Ambition
- ✓ A clear strategy for developing our business



Strategic enablers

...to take us to the next level

- Sales growth faster than the market¹
- Comparable EBITA margin of 12-15%²
- Climate targets
- Improved resilience through service growth
- Increased employee engagement

¹nominal world GDP growth, IMF World Economic Outlook

²as soon as possible, but no later than in 2027. Profitability range, depending on the cycle.

Our capital allocation priorities



Capital expenditure

Reinvesting into own operations to grow the business and improve productivity



Dividends

Distributing profits to shareholders according to the dividend policy

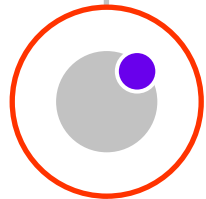

Acquisitions

Strengthening the business with bolt-on and adjacent acquisitions



Debt repayment

Maintaining a strong balance sheet with the debt level below the gearing ceiling target



3. Key financials development



Order intake

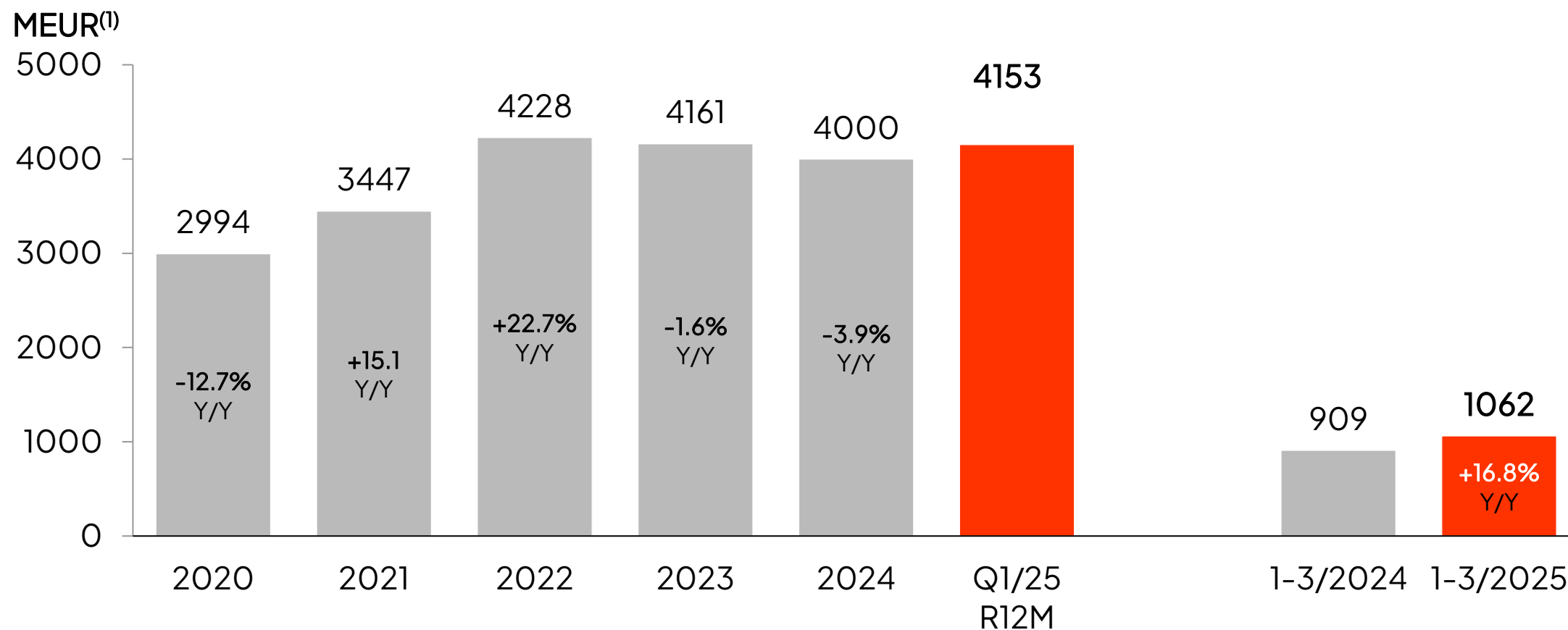

Note (1): Agreement base included in orders received from Q1 2023 onwards and historical figures are restated

Net sales

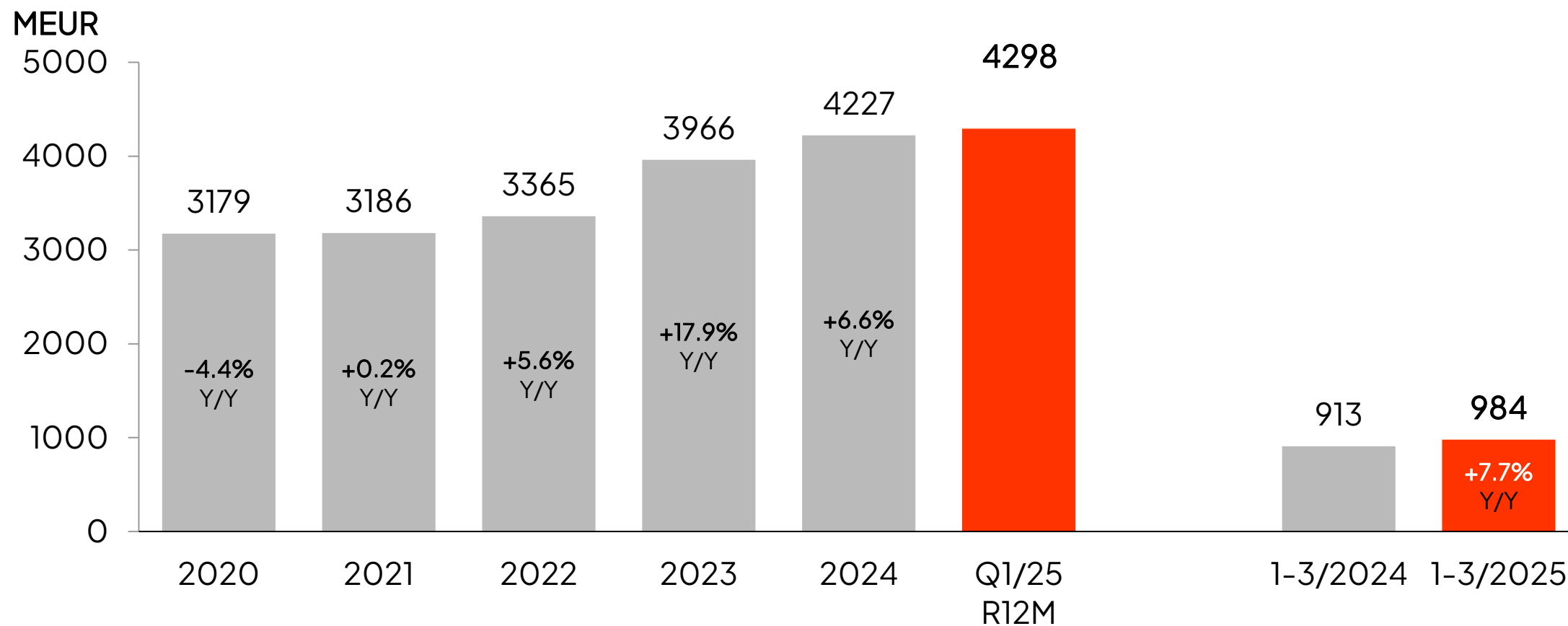

Comparable EBITA margin

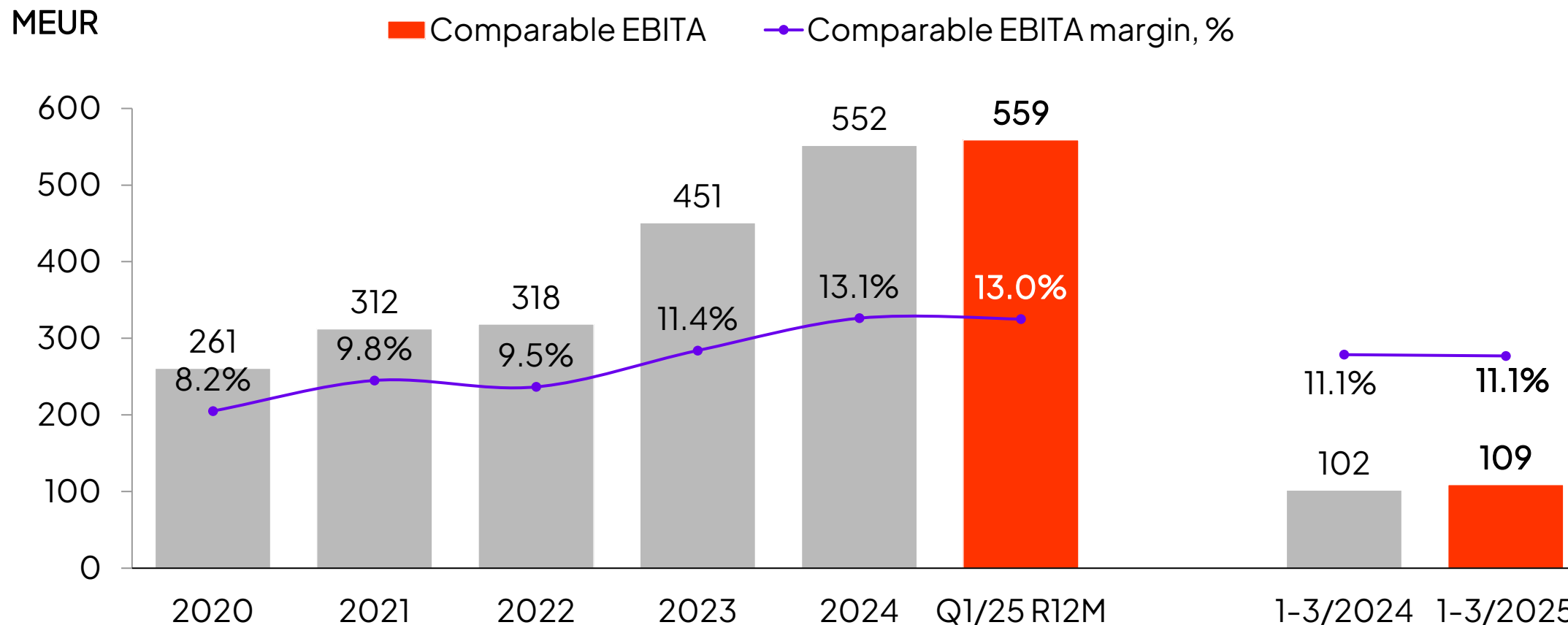

Orderbook

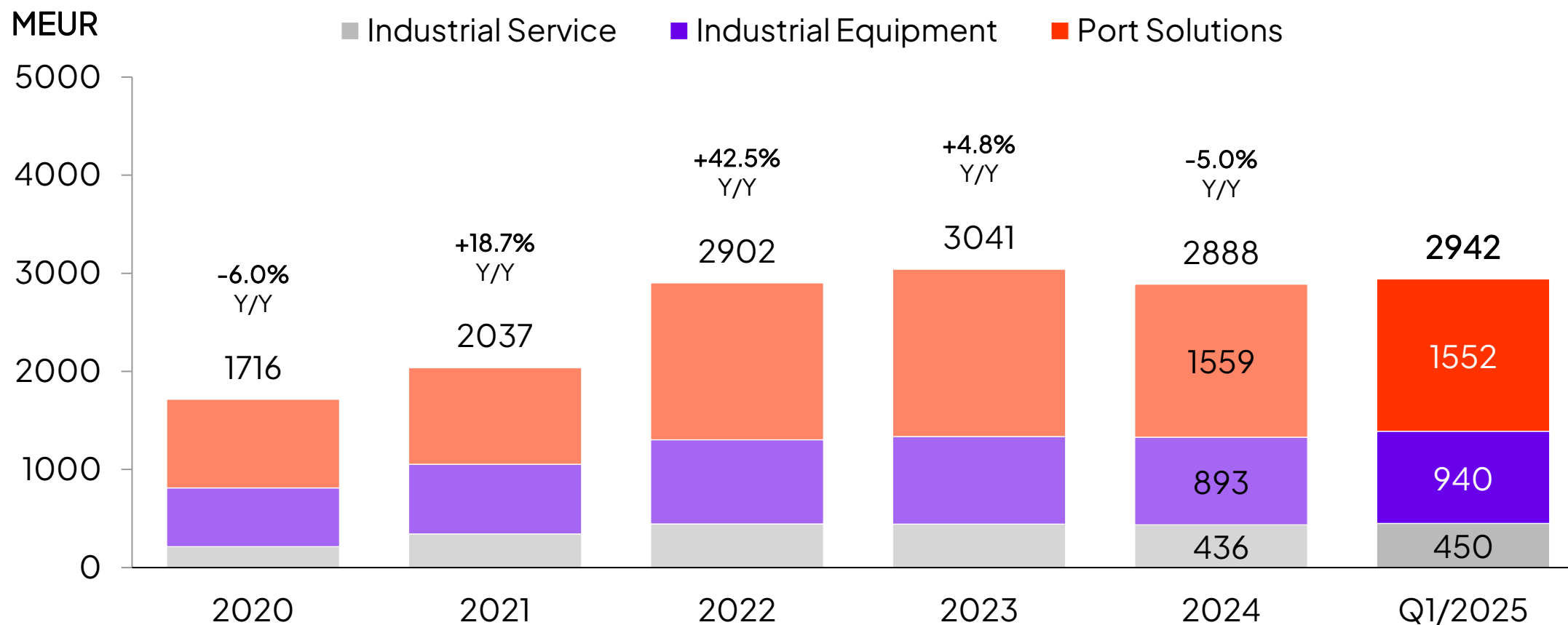

4. Konecranes as an investment

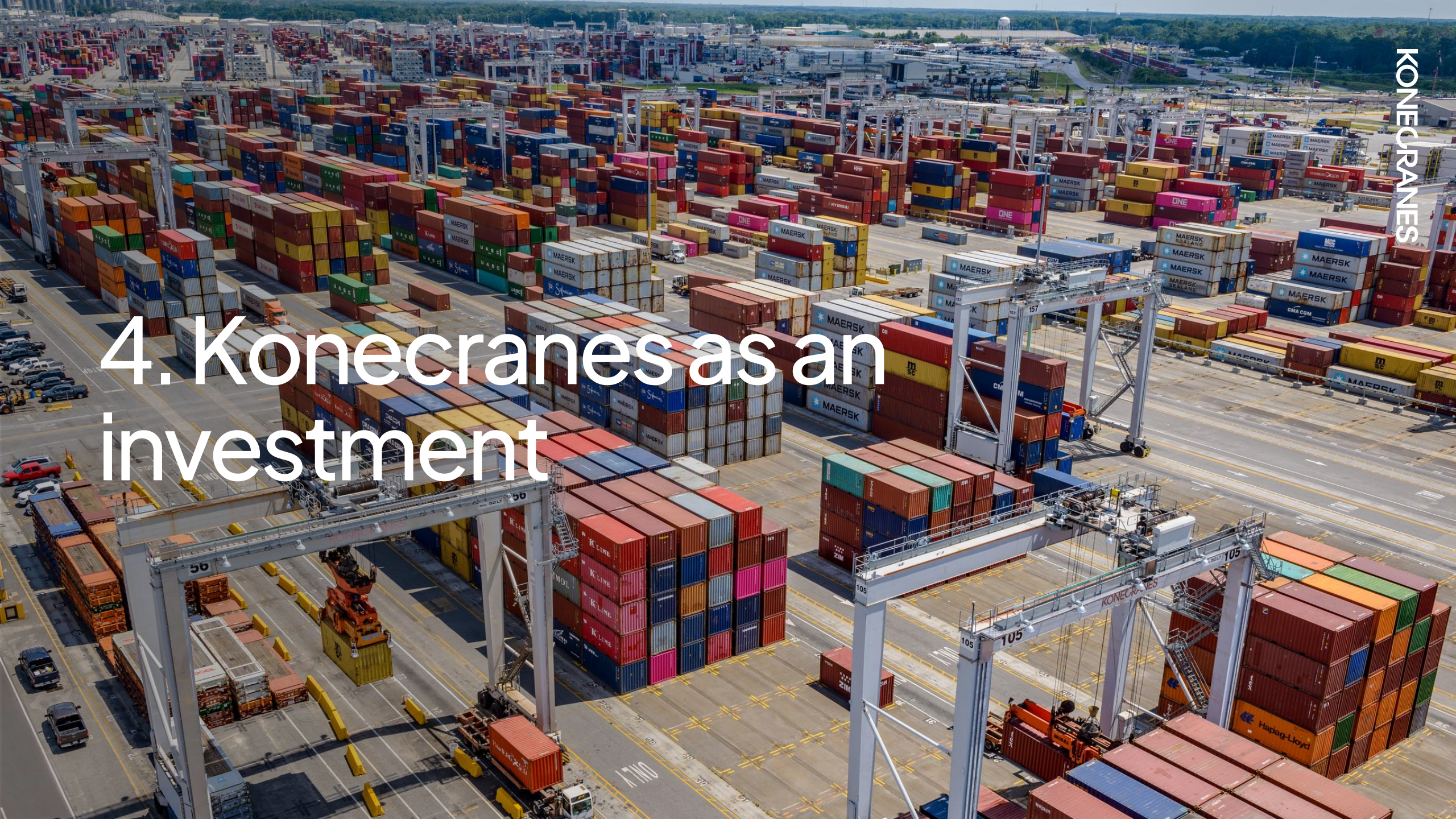

Konecranes as an investment

Leader in technology

Strong market position in all Business Segments

Attractive opportunities for growth

Profitability target for 12-15% Group comparable EBITA margin

Solid financial position and dividend

Long-term commitment to sustainability

With many innovative solutions and a solid patent portfolio, we are a technology leader in our industry

Own in-house developed Core of Lifting...



GEARS



MOTORS



CONTROLS

...key componentry with optimized design, smarter features, better reliability...

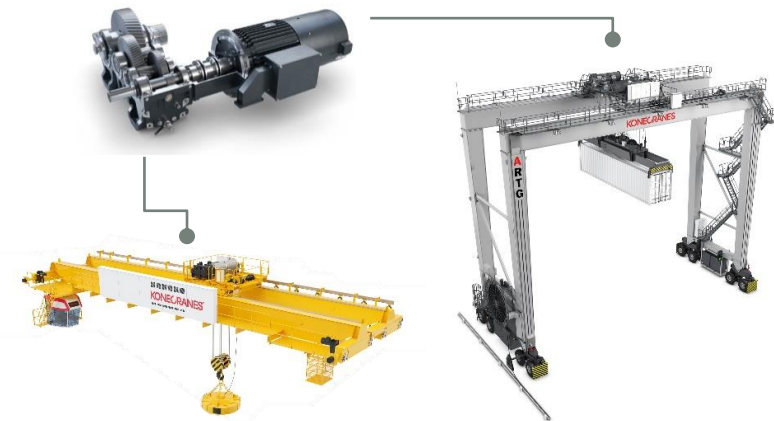

...and used across the whole product range

Smart features & digitalized offering for improved safety and productivity

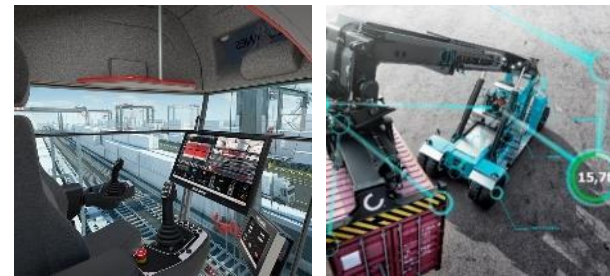

Access to massive data streams and real-time connectivity enables preventive and predictive maintenance solutions for highest lifecycle value

Konecranes Smart features

Active sway control	Hook centering	Slack rope prevention	Follow me	Assisted load turning
Shock load prevention	Load floating	Snag prevention	End positioning	Target positioning
Extended Speed Range	Tandem drive	Hook leveling	Synchro	Sway control
Working limits	Protected areas	Micro speed	Inching	
TRUCONNECT Remote diagnostics	TRUCONNECT Efficiency monitoring	TRUCONNECT Remote monitoring	TRUCONNECT Safety alerts	

We have a strong market position in all of our three segments



Industrial Service

- Our global branch network is unique in the industry – there is **no global or regional competition** in industrial crane maintenance



Industrial Equipment

- Our family of leading brands secures our position as the **global market leader** in industrial cranes



Port Solutions

- We rank market **number 1-3** in **all product categories** for port and container terminals

Illustrative competitive landscape

Company	Country	Industrial cranes	Port cranes	Lift trucks	Service
Columbus McKinnon	USA	●			●
Kito	Japan	●			
Abus Kransysteme	Germany	●			
GH	Spain	●			●
OMIS	Italy	●			●
Weihua	China	●			
ZPMC	China		●	●	●
Kalmar	Finland		●	●	●
Liebherr	Germany		●	●	●
Taylor	USA			●	
CVS Ferrari	Italy			●	
Mitsui E & S	Japan		●		
Kunz	Austria		●		
Hyster	USA			●	
Sany	China		●	●	

Konecranes is a global leader in material handling solutions, serving a broad range of customers across multiple industries

Megatrends driving our business



Demand drivers

- The world is facing an increasingly acute challenge to provide materials and goods that are essential for people while preserving scarce resources and limiting emissions
- Demand driven by market conditions in manufacturing industries and container handling industry
- New equipment investments to expand capacity or replace old existing equipment
- New investments are cyclical and varies depending on the economic environment
- Increasing demand for higher productivity, safety and eco-efficiency presents growth opportunities

Industrial Service

Sales growth clearly faster than the market¹

- Service Programs renewal / Agreement base expansion
- Enhanced customer experience/journey
- Commercial Excellence / Price Management
- Continued optimization of sales and service delivery
- Equivalent Parts for third party equipment
- Bolt-on acquisitions

Industrial Equipment

Sales growth in line with the market¹

- Focus on improving profitability
- Global leader in sustainable lifting solutions
- Comprehensive offering of standard equipment and process cranes for a full range of industrial applications
- Diversified customer base across industries & geographies

Port Solutions

Sales growth clearly faster than the market¹

- Widest and deepest offering provides good opportunities for growth and to increase market share
- Clear growth plan for Port Services
- Automation and customers' commitments to sustainability drive growth, and we have leading offering

¹nominal world GDP growth, IMF World Economic Outlook

Comparable EBITA margin of 12-15% as soon as possible, but no later than in 2027

Group
Target: 12-15%⁽¹⁾

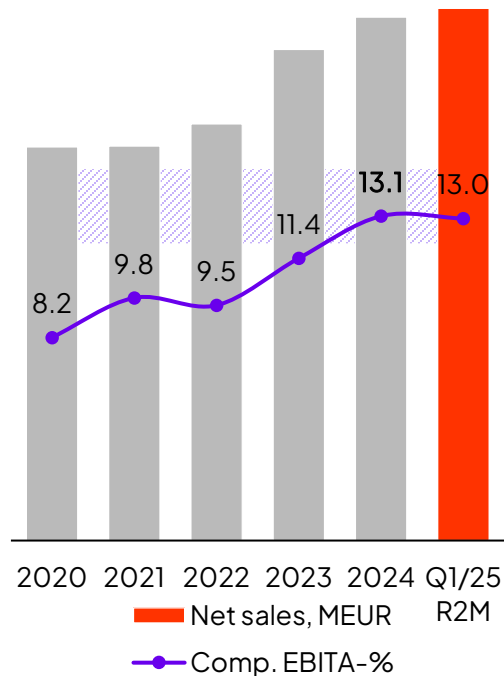

Industrial Service
Target: 20-24%⁽¹⁾

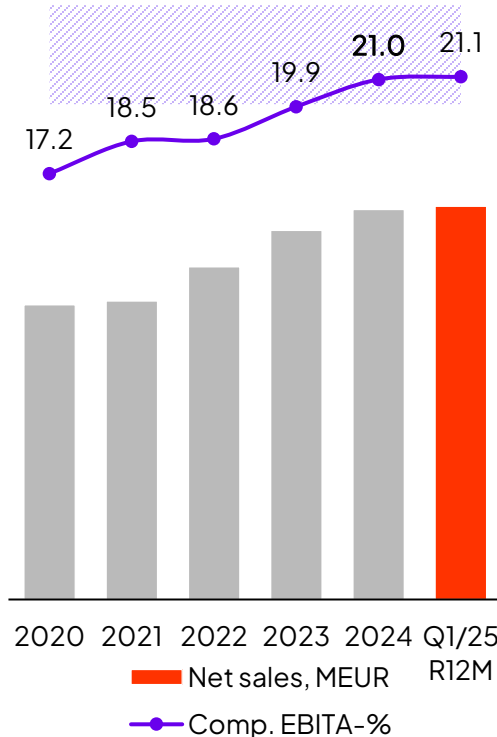

Industrial Equipment
Target: 8-10%⁽¹⁾

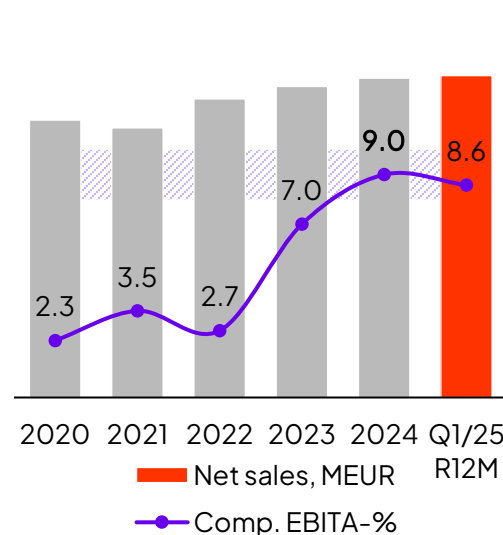

Port Solutions
Target: 9-11%⁽¹⁾

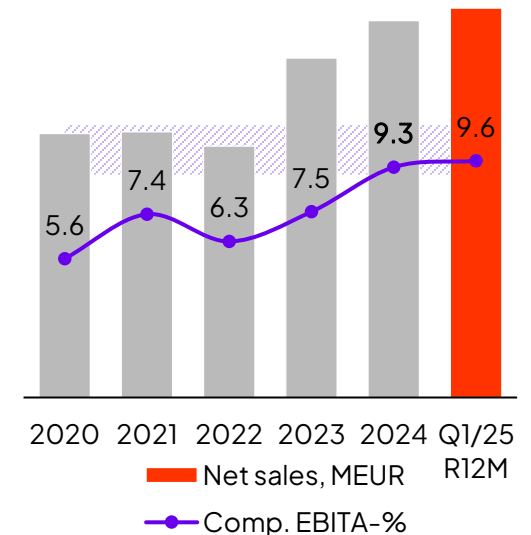

Note (1): Profitability range, depending on the cycle

A healthy balance sheet enabling long-term development & growth, and a stable to increasing dividend to shareholders

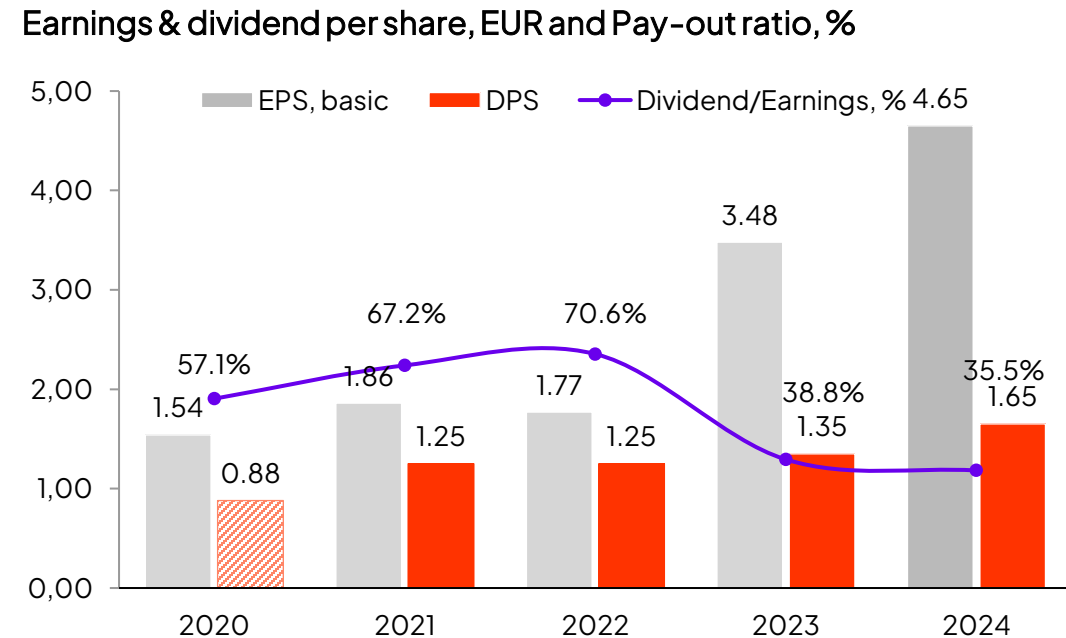
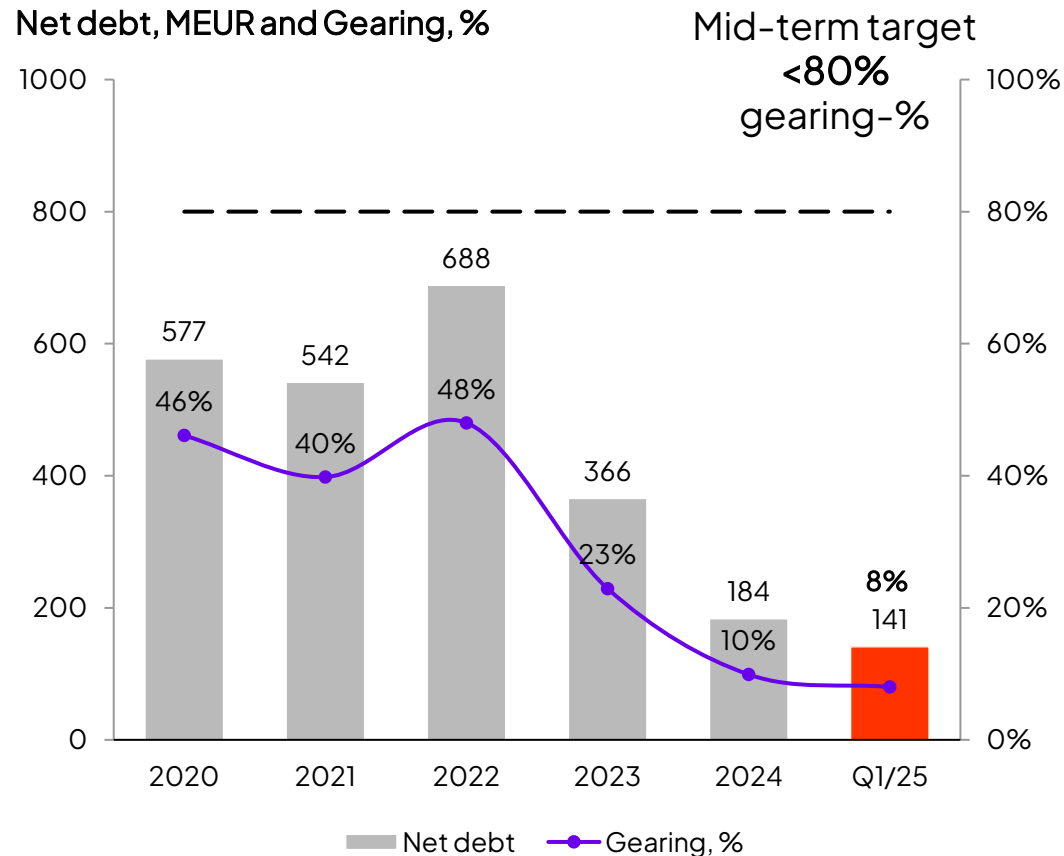

Konecranes aims to pay a stable to increasing dividend per share, over the cycle

Note (1): For 2020, the dividend was in accordance with the Combination Agreement, the planned merger with Cargotec was cancelled in Mar-2022

Konecranes works for a decarbonized and circular world

Konecranes' climate targets

Million tons of CO₂e

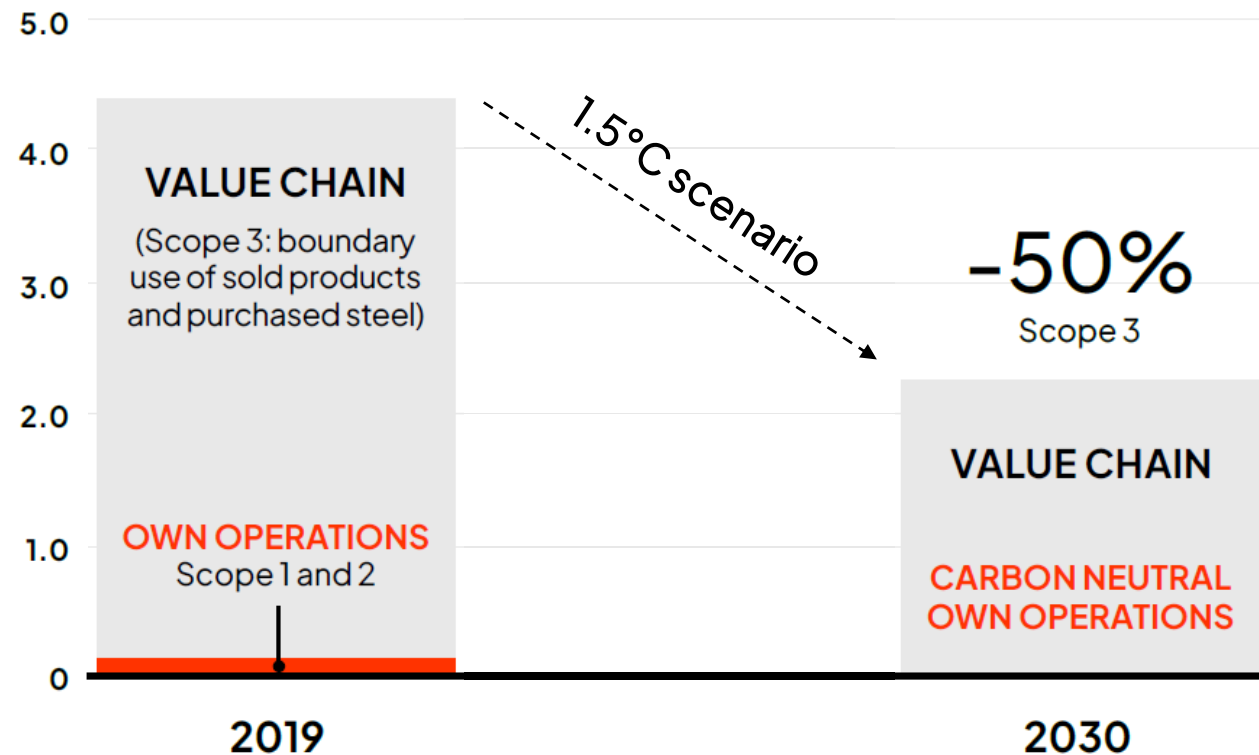

Key focus areas

Electrification of diesel-powered equipment

Smart product design focusing on energy efficiency, durability and maintainability

Optimizing material handling with automation and digital solutions

Purchasing steel with minimum emissions

Focusing on energy efficiency and renewable energy, and offsetting the unavoidable emissions of own operations

Note: All Konecranes' sustainability targets are listed on Konecranes' Investors website: <https://investors.konecranes.com/sustainability> and in the Sustainability Report

Konecranes as an investment

1. LEADER IN TECHNOLOGY

- Own key componentry: gears, motor and controls enable optimized design, smarter features and better reliability.
- Digitalized product offering for improved safety and productivity.
- Access to massive data streams and real-time connectivity enables preventive and predictive maintenance solutions for the highest lifecycle value.

2. STRONG MARKET POSITION IN ALL BUSINESS SEGMENTS

- In Service, we are the market leader with our unique global service branch network and unmatched offering. There is only limited global or regional competition in industrial crane maintenance.
- Our family of leading brands secures our position as the global market leader in industrial cranes.
- We rank #1-3 in the market in all product categories for ports and container terminals.

3. ATTRACTIVE OPPORTUNITIES FOR GROWTH

- We aim to grow our sales faster than the market¹⁾
- Significant growth potential in Service with the expansion of Konecranes' unparalleled service offering to our own as well as third-party installed base.
- Automation and customers' commitments to sustainability, as well as our widest and deepest offering provide good opportunities for growth in Port Solutions.

1) Nominal world GDP growth, IMF World Economic Outlook

4. PROFITABILITY TARGET FOR 12-15%²⁾ GROUP COMPARABLE EBITA MARGIN

- To be reached as soon as possible, but no later than in 2027.
- Margin improvement mainly driven by sales growth in Service and Port Solutions.
- Margin improvement mainly driven by simplification of go-to-market model and product platform harmonization in Industrial Equipment.

2) Profitability range, depending on the cycle

5. SOLID FINANCIAL POSITION AND DIVIDEND

- Healthy balance sheet, providing a good base for long-term development and growth.
- Konecranes aims to pay a stable to increasing dividend per share, over the cycle.
- For the 2008-2023 period, the average dividend pay-out ratio was 88 percent of earnings.

6. LONG-TERM COMMITMENT TO SUSTAINABILITY

- We enable a decarbonized and circular world.
- We deliver safe and secure material handling solutions.
- We create a fair, inclusive, diverse and engaging working environment.
- We expect the highest ethical standards of ourselves and our business partners.
- Konecranes aims to have carbon neutral own operations by 2030 and continues the work to reach its science-based targets, in line with limiting global warming to 1.5°C.

5. Business Area overviews



5. Business Area overviews

Industrial Service



Industrial Service in brief

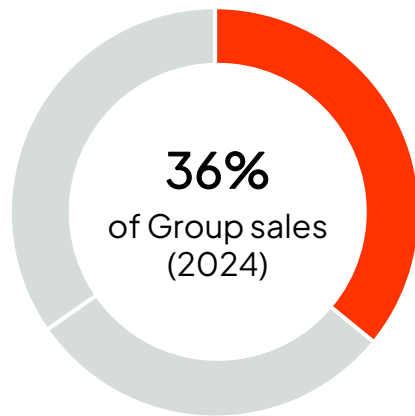

7,963
employees (end of Q1 2025)

1,574.7
net sales, MEUR (2024)

21.0%
comp. EBITA margin (2024)

- Konecranes is a market leader in crane service with one of the world's most extensive service networks
- Service provides industry-leading maintenance services for all types and makes of industrial cranes and hoists
- Our objective is to improve the safety, productivity and sustainability of our customers' operations
- Lifecycle Care is our comprehensive and systematic approach to managing customer assets; we connect data, machines and people to deliver a digitally-enabled customer experience in real time

Key financials, MEUR

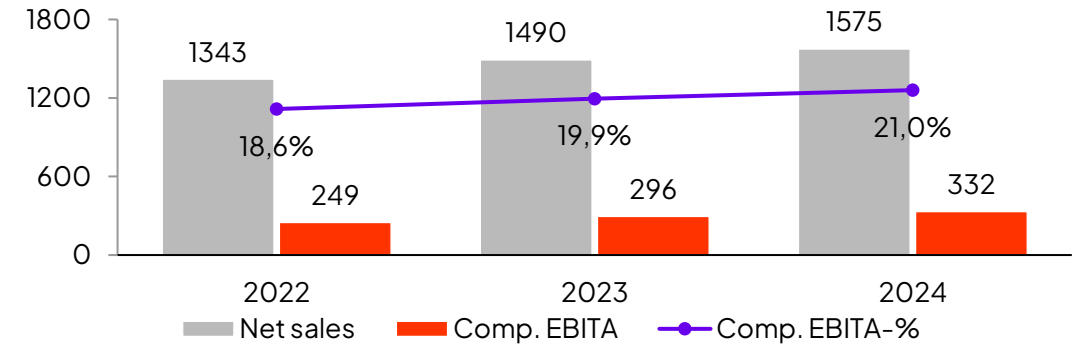

Orders received and agreement base, MEUR⁽¹⁾

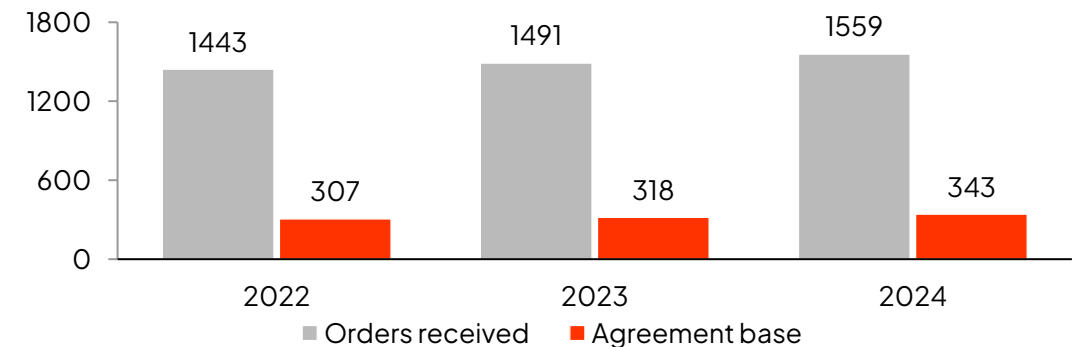

Note (1): Agreement base included in orders received from Q1 2023 onwards and historical figures are restated

Working as one customer-centric team

Service actions starting to deliver growth



INDUSTRIAL SERVICE

- Service Programs renewal / Agreement base expansion
- Enhanced customer experience/journey
- Commercial Excellence / Price Management
- Continued optimization of sales and service delivery
- Equivalent Parts for third party equipment
- Bolt-on acquisitions

Service sales growth clearly faster than the market¹
Comparable EBITA margin of 20-24%²

Status Update

- Revised programs / tools launched. Implementation continues.
- Customer portal launch started for Alpha and Beta
- On-going. Spare parts pricing harmonization completed
- Predictive maintenance, planning and tech tools launched
- Offering continues to expand
- Bolt-on acquisition funnel building

Sales growth and EBITA margin development as per plan

¹nominal world GDP growth, IMF World Economic Outlook

²as soon as possible, but no later than in 2027. Profitability range, depending on the cycle.

Market leader with our unique global service branch network and unmatched service offering

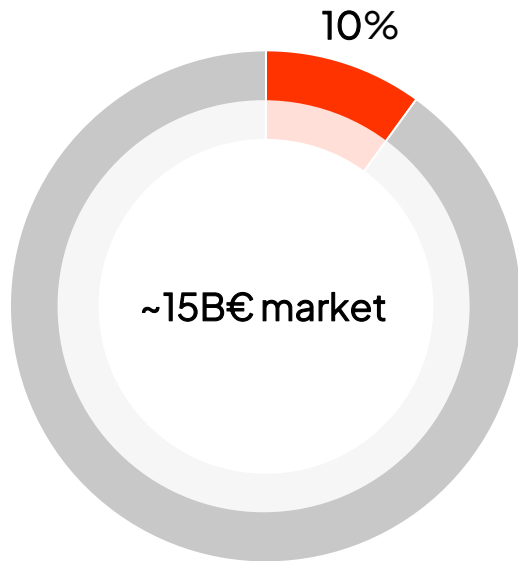

Industrial Service market

Service market size/market share includes all maintenance services both insourced and outsourced. Service scope based on current Konecranes scope.

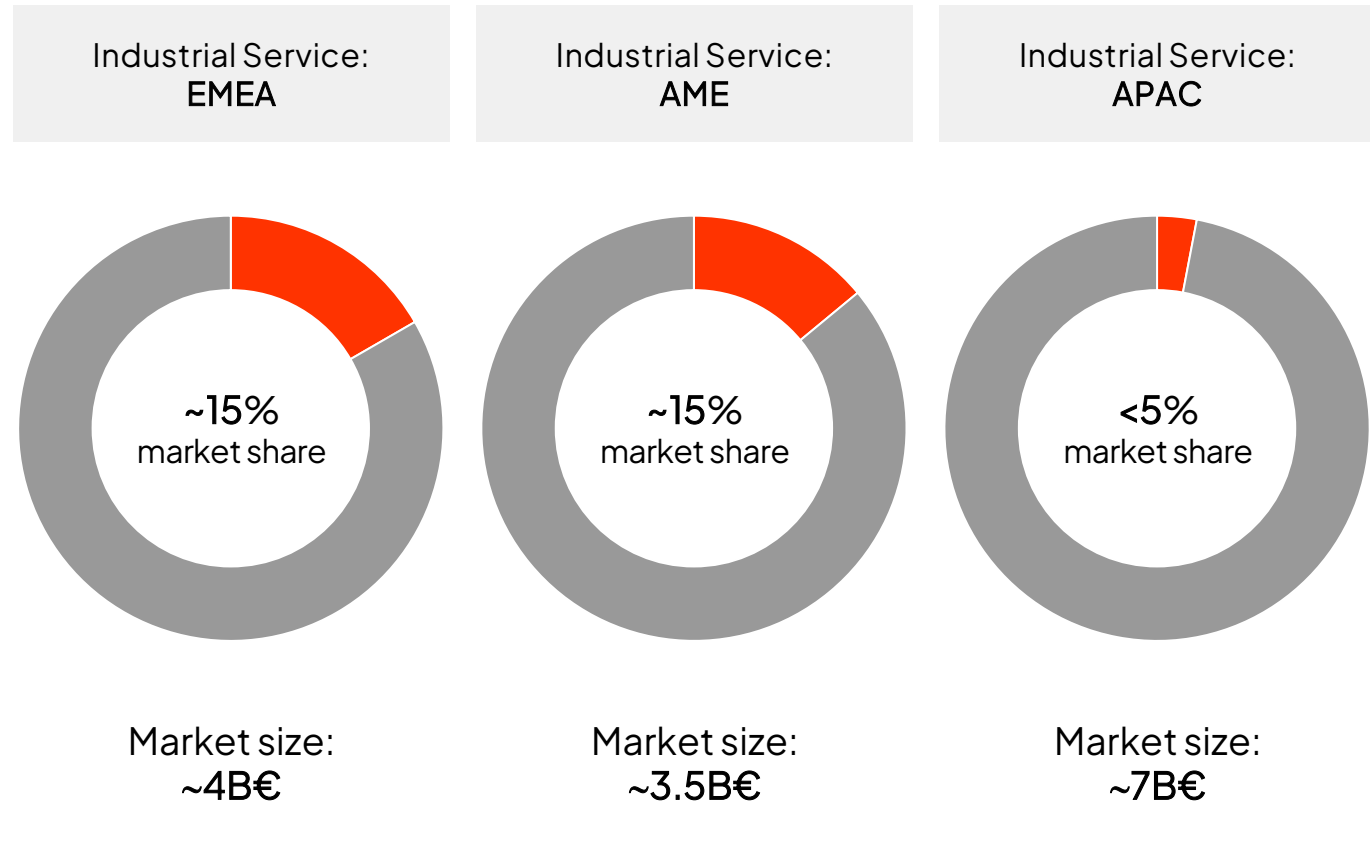

Industrial Service business model – managing assets throughout the lifecycle

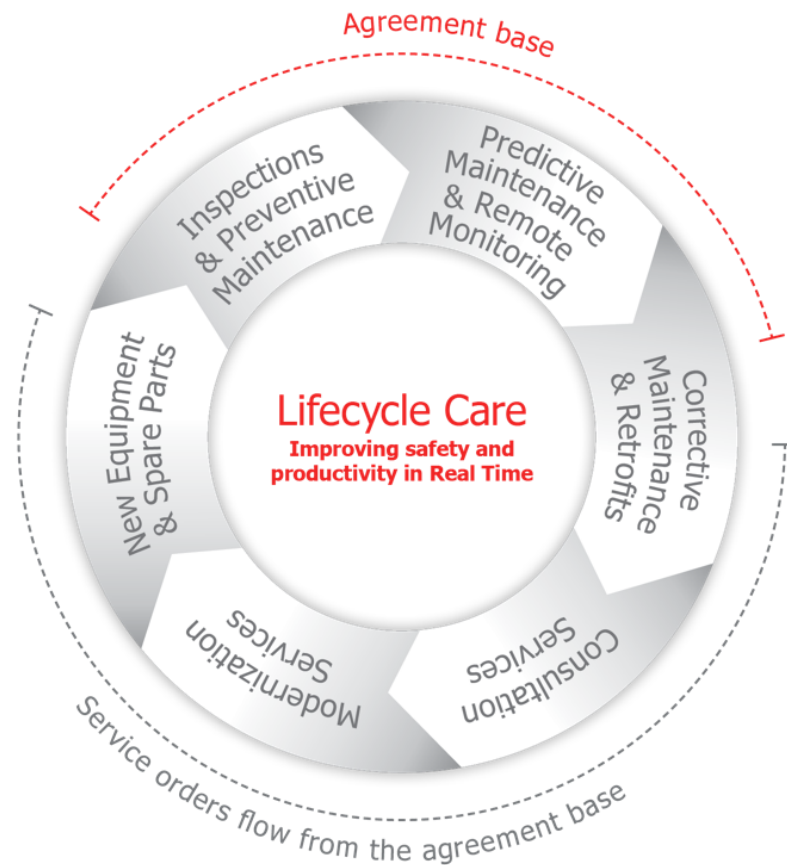

~20% of sales

Inspections, Preventive Maintenance, Predictive Maintenance Agreement Sales, Inside Sales
 New business development and renewals
 Lead generation

~30% of sales

Corrective Maintenance
Inspector, Technician, Inside Sales
 Advice based on findings and condition monitoring – speed
 Lead generation

~25% of sales

Retrofits, Consultation Services, Mods, Lifting Equipment
Service Sales, Inside Sales
 Consultative selling, analytics driven lead generation

~25% of sales*

Spare Parts & Accessories
Inside Sales, eCommerce
 Transactional, convenient

* Includes all channels (direct & indirect)

Agreement base breakdown by hoist brand and coverage ratios by asset brand

Agreement base / breakdown by hoist brand

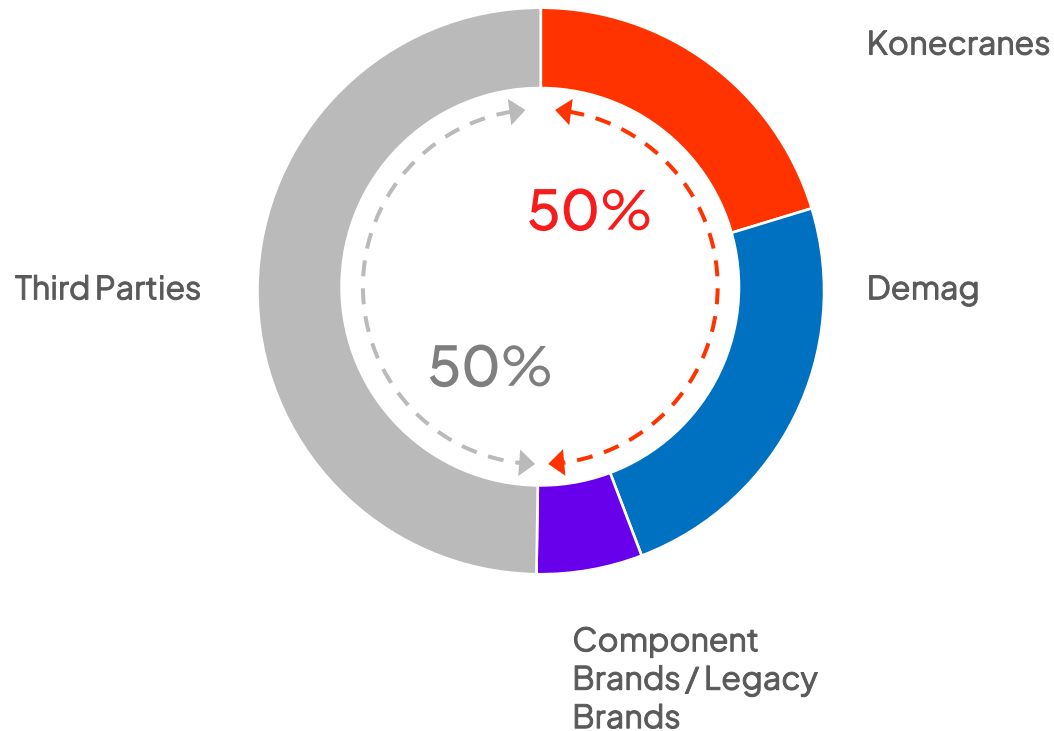

- Approximately 50% of the hoisting machinery in our agreement base was manufactured by the Konecranes Group; the other 50% by third parties.
- Hoists can be replaced when they reach the end of their service life or even before then in order to improve safety, productivity and sustainability and/or reduce maintenance costs.
- Agreement base coverage is 50-55% for both Konecranes and Demag branded hoists
- After the warranty period, coverage ratio is somewhat higher, 60-65%
- Coverage is based on the estimated asset installed base in operation. Asset generally refers to the crane: industrial crane, light crane system, jib crane, etc.
- A single asset may have multiple hoists. Hoists have a much shorter life than the crane (structure). Hoists may be replaced several times over the life of the crane.

Achieving organic Industrial Service growth

1. Expand agreement base

- Renewed/targeted Service Programs
- Comprehensive agreements for critical/production assets with larger accounts
- Enhanced customer experience driving customer retention

2. Continuously improve sales efficiency, planning and service delivery

- Sales model evolution - leveraging inside sales and customer support
- “Smart” planning tools, automated quotations, and configurator enhancements
- Next generation field mobility tools and parts delivery concept

3. Expand focus on third party equipment

- Equivalent replacement parts
- Hoist and component replacements, retrofits and modernizations
- New equipment (light lifting equipment and cranes)

Improved Agreement Quality

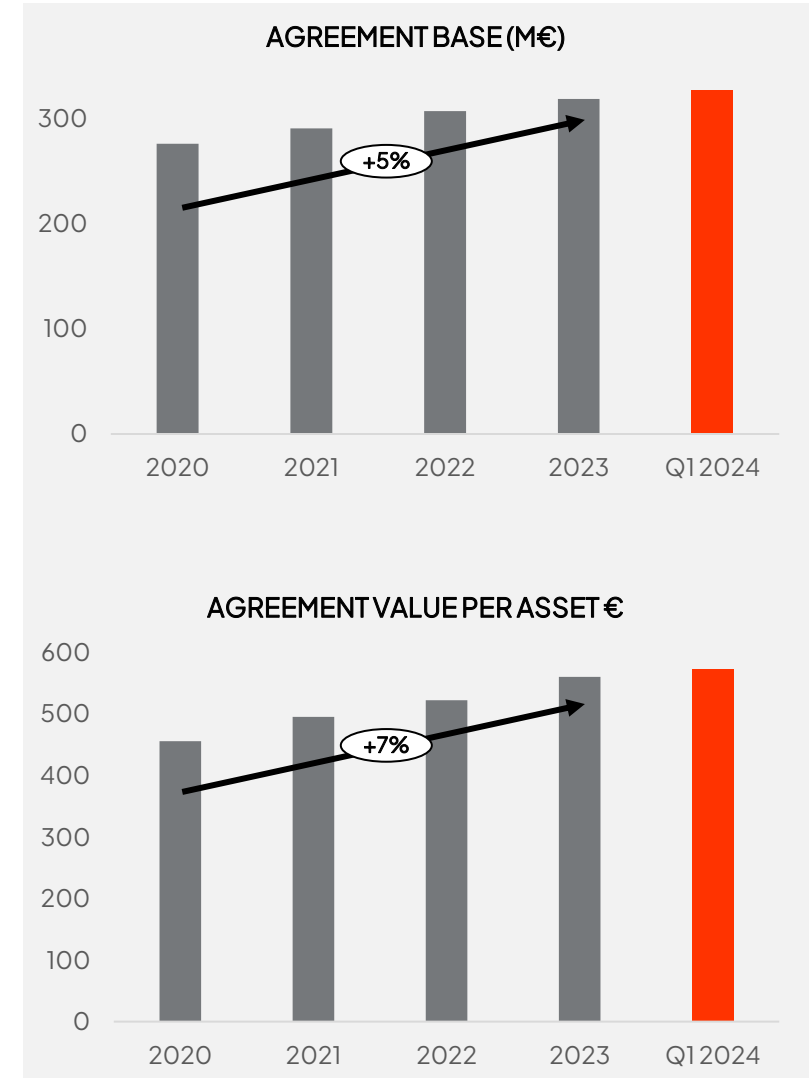

Renewed Service Programs – each tailored to a different customer segment to enhance customer experience and retention



CONDITION

Inspection/Routine Maintenance Program

Addresses safety and compliance requirements and is streamlined with a digital and automated process.



CARE

Preventive/Predictive Maintenance Program

Optimize asset performance and improve safety, productivity and sustainability with digital and advanced services to support predictive maintenance.



COMMITMENT

Comprehensive Maintenance Program

Outsourced asset management is tailored to industry and application requirements to achieve the highest lifecycle value.



COMPLETE

Comprehensive Maintenance & Operations Program

Complete outsourcing of equipment maintenance and operation, collaboration to establish material handling and performance objectives and extend lifecycle value and total cost of ownership for the entire operation.

Digital enablers in Industrial Service – Helping us enhance the customer experience and to deliver services more efficiently

Unified customer portal

- Engaging content focused on customer needs
- Self-service tools for quicker contact and support
- Full relationship view

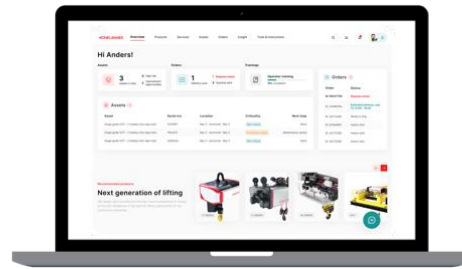

Customer engagement / sales enablement / offer configuration

- Consolidated customer account information in one view with visibility to sales cases, service requests, etc
- Configure quotes and share relevant content to customers

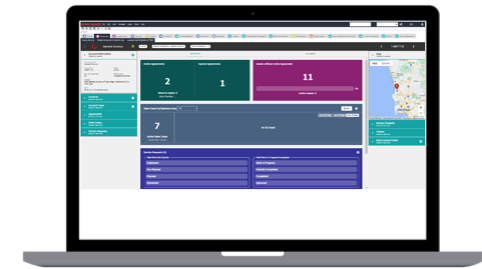

Smart planning

- Schedule work aligned with technician proximity, skill and material availability
- Optimized for most efficient customer response time

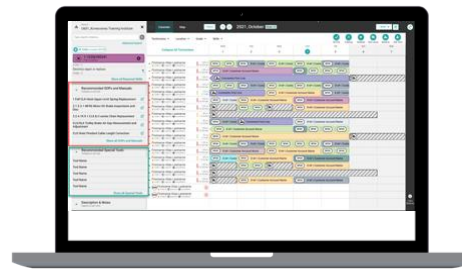

Next generation mobility apps for field operatives

- Guides behavior, provides feedback, and ensures process adherence
- Intelligent troubleshooting platform helps diagnose and repair in the field
- Live tech support available via video



Acquisition opportunities across various sectors



BOLT-ON ACQUISITIONS

- Targeting installed base, service opportunities
- Adding certain customer segments and field technical resources
- Able to quickly integrate creating significant synergy potential
- Recent cases: Whiting, Munck



NEW MARKET ENTRY / EXPANSION

- Significant markets where we have little or no presence



TECHNOLOGIES / CAPABILITIES

- Industrial automation, systems integration, material flow simulation
- Opportunity to offer a holistic solution to the customer to optimize production and intralogistics
- Recent case: Crane Automation Technology Systems



COMPLEMENTARY PRODUCTS & SERVICES

- Manual products, slings and accessories, industrial inspections
- Many of these products and services are currently being offered but not to a wide extent

Technicians are at the heart of our success and key to our growth

IMPROVE PRODUCTIVITY

Field operative time and tasks focused on our customers and their assets



INCREASE RETENTION

Continuously improving the employee experience



ACTIVELY RECRUIT

Always searching for our future talent



5. Business Area overviews

Industrial Equipment



Industrial Equipment in brief

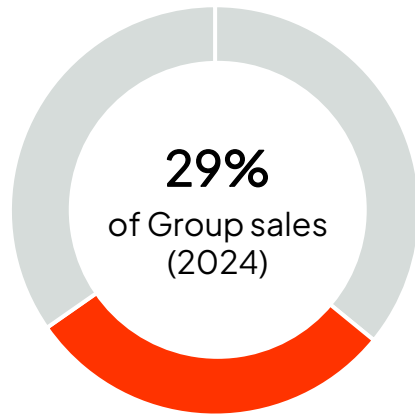

5,214
employees (end of Q1 2025)

1,289.3
net sales, MEUR (2024)

9.0%
comp. EBITA margin (2024)

- Konecranes is one of the world's largest suppliers of industrial cranes and wire rope hoists and a technology leader with digital controls, software and automation
- Industrial Equipment offers hoists, cranes and material handling solutions for a wide range of customers from General Manufacturing to various kinds of process industries like Waste-to-Energy, Paper and Forest, Automotive and Metals Production
- Products are marketed through a multi-brand portfolio

Key financials, MEUR

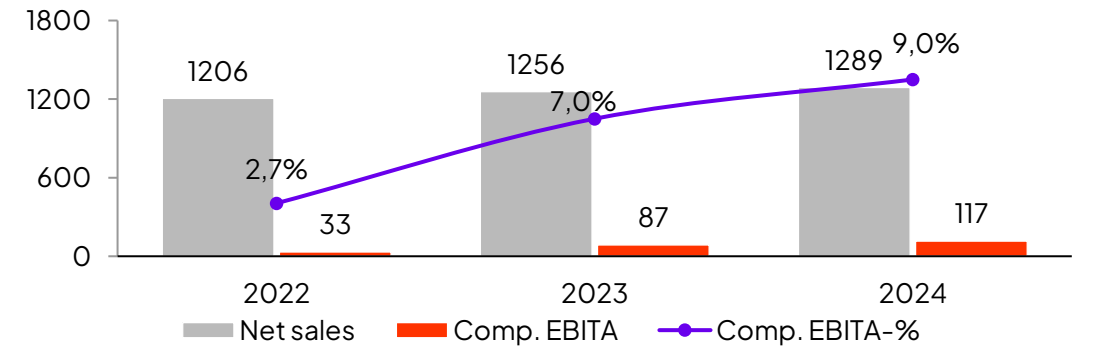

Orders received and order book, MEUR⁽¹⁾

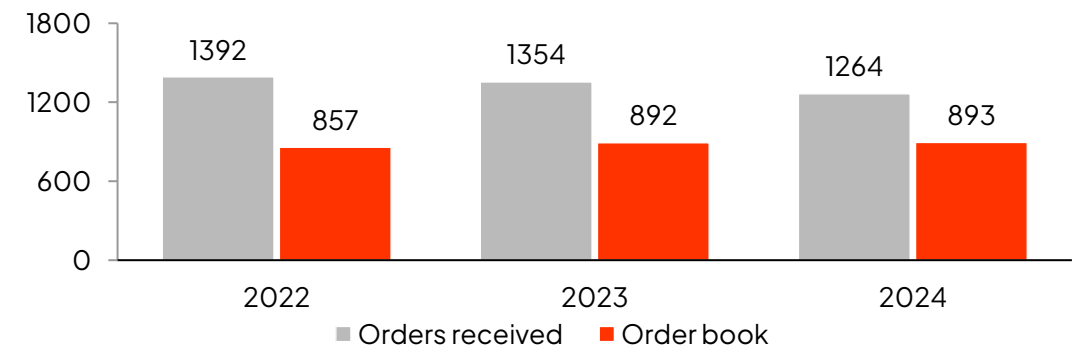

Note (1): Agreement base included in orders received from Q1 2023 onwards and historical figures are restated

Working as one customer-centric team

Equipment actions driving improved profitability

EQUIPMENT

- Go-to market / operating model simplification
- Platform harmonization/rationalization
- Commercial Excellence / Price Management
- Renewed offering
- Supply chain efficiency / Operational Excellence

- Portfolio optimization

Equipment profitability: comparable EBITA margin of 8-10%²

Sales growth in line with the market¹

¹nominal world GDP growth, IMF World Economic Outlook

²as soon as possible, but no later than in 2027. Profitability range, depending on the cycle.

Status Update

- Largely completed. Demag moved to Alpha
- On-going. Several platforms ramped-down
- On-going. Various programs in both/across sales channels
- On going. WRH and ECH platforms launched. LCS expanded
- Supply transformation in Wetter executed/on-going.
- Two crane factories shut down; one right-sized.
- IPD divested

EBITA margin expansion as per plan



Global market leader in industrial cranes

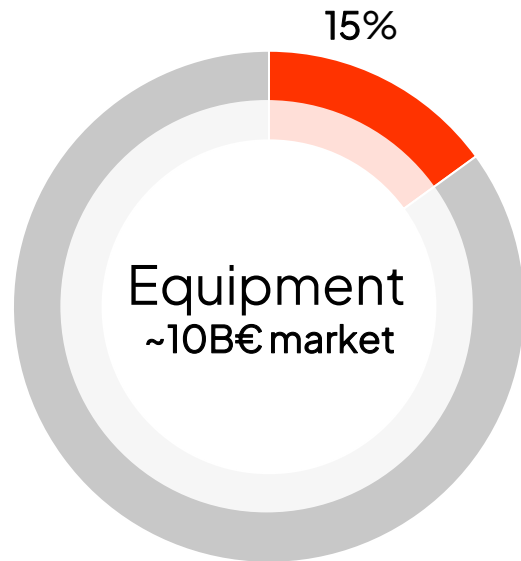

Industrial Equipment market

Equipment market share is adjusted for hoist and component packages sold through Alpha channel i.e., equivalent “crane units.”

¹ Market share of CTO/WRH includes estimated crane volume from sold hoists through the Alpha channel. 15% of sold solo hoists are assumed to be for replacement purposes and a crane would need in average 1.15 hoists.

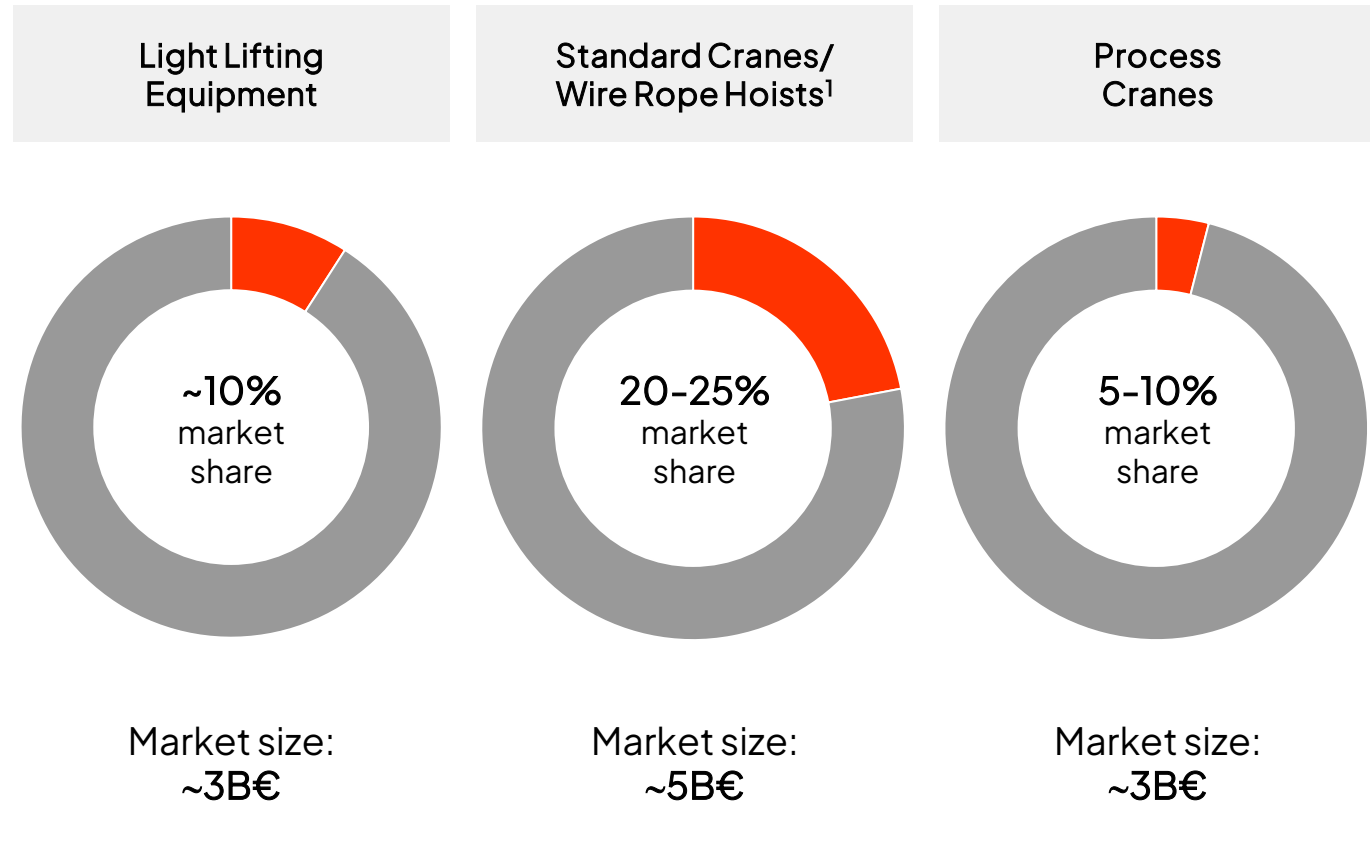

Industrial Equipment offering – leading provider of industrial cranes

Components



DEMAG **R&M** **SWF** **VERLINDE** **donati**

Hoists
(Wire rope hoist, electric chain hoist and winches)



Core of Lifting
(Gears, Motors, Controls)



Crane kit packages





Other components

Standard Cranes



Overhead cranes
(Configured-to-order, CTO)



Light crane systems / Workstation lifting systems
(workstation cranes, electric chain hoists, jib cranes)



Products for hazardous environments



Other industrial products

Process Cranes (Engineered-to-order)



Waste-to-energy & Biomass



Automotive



Power & Nuclear



Paper & forest



Petroleum and gas



Metals production

Dual channels with shared equipment platforms ensure market coverage, drive economies of scale and enhance profitability

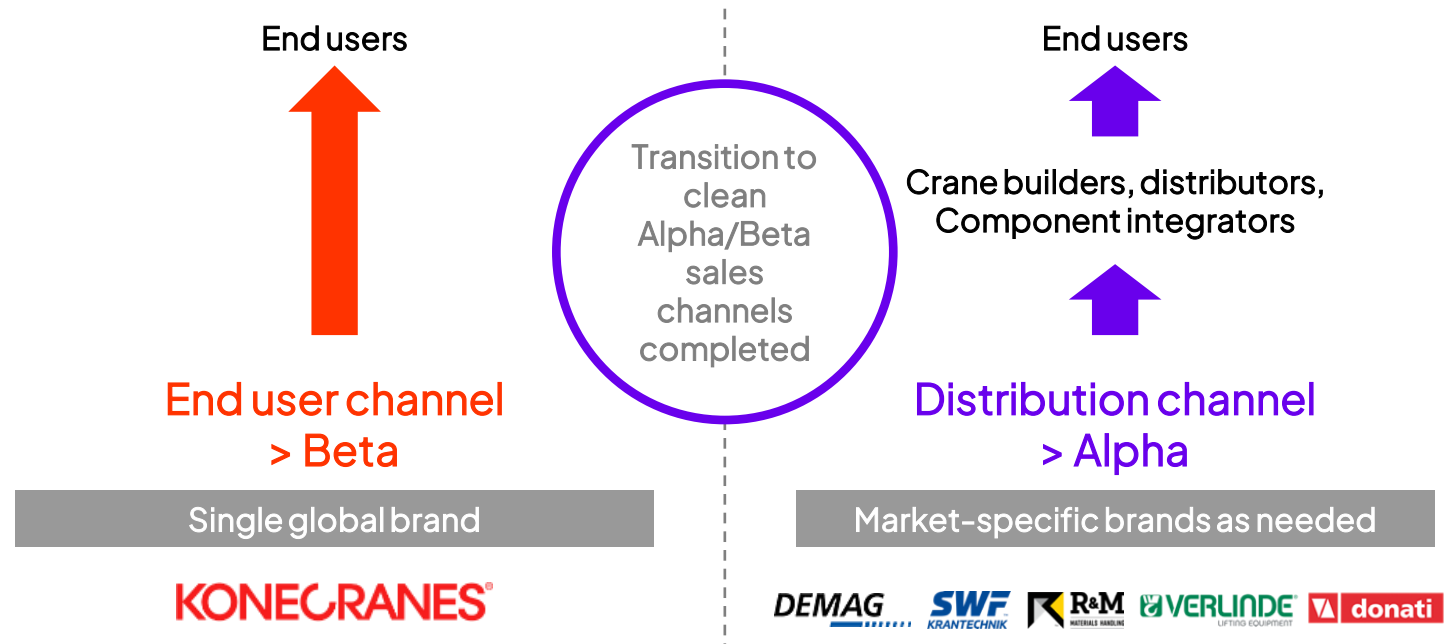

Focused and clearly defined sales channels, brands and offering with dedicated teams for direct (end user) and indirect (distribution) channels



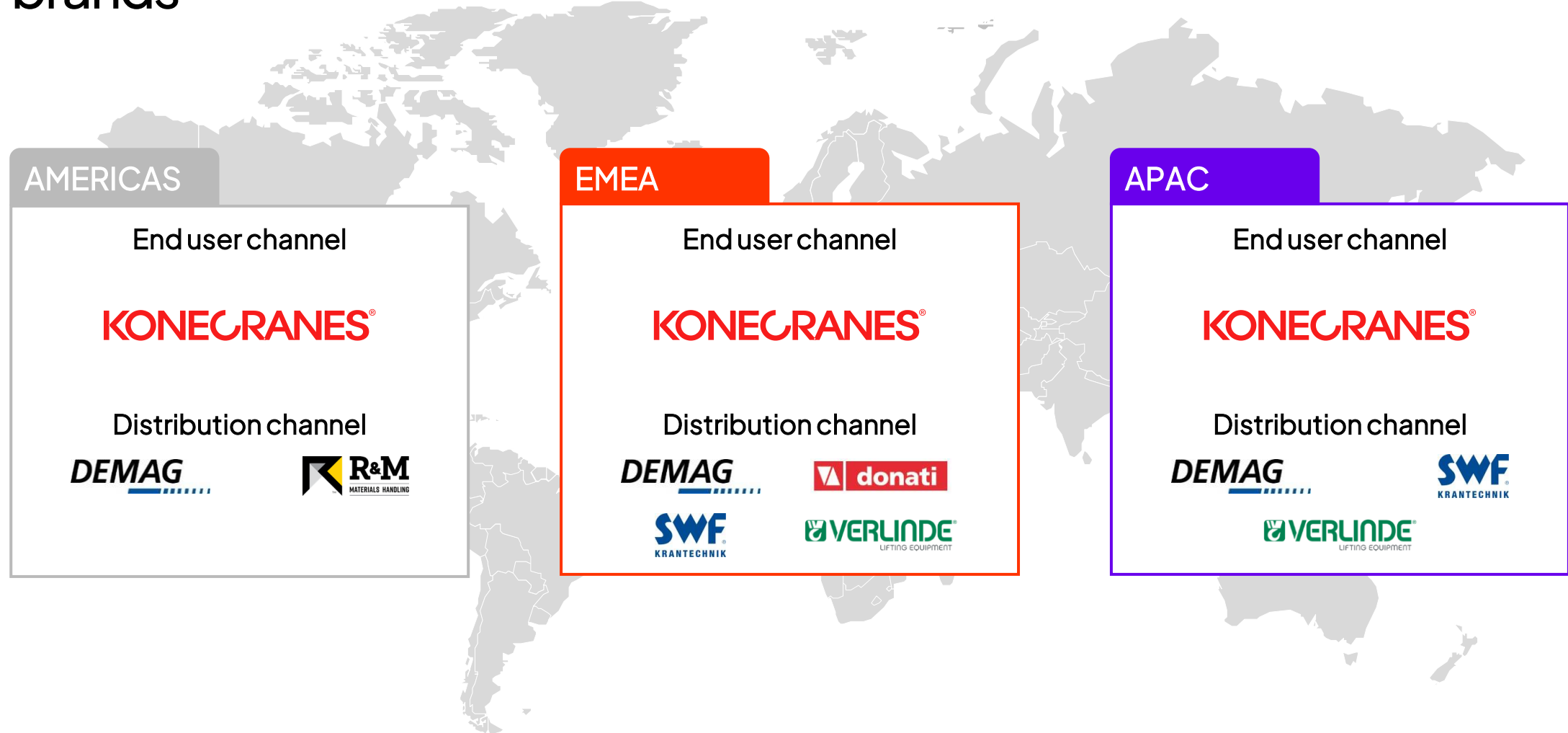

- Industrial Equipment consists of three businesses: Components, Standard cranes, and Process cranes
- On average, in the long-term and over the cycle, Industrial Equipment’s sales split has typically been approximately:
 - Components business around 25-30%
 - Standard cranes business around 50%
 - Process cranes business around 20-25%

Global presence with strong portfolio of leading industrial crane brands



Product harmonization and digitalization drive profitability

Core of Lifting “purpose built” components enable competitiveness and economies of scale

Product offering	Platforms 2018	Platforms 2024*	Target 2027	Benefits of scalability
			Global platforms*	
Electric Chain Hoist 	4	3	1	Cloud services Data driven value
Light Crane Systems 	3	1	1	Crane software layer Intelligent control, advanced features, connectivity, Digital CX
Standard Wire Rope Hoist 	6	2	1	Electrical system Scalable common architecture across the product lines
Winch 	7	5	1	Mechanical structure A solid platform fulfilling market criteria
Standard Cranes 	2	1	1	

*NOTE: Excludes local/niche/special application products

Next Generation Light Lifting Equipment

Delivering growth opportunities and enhanced profitability

New Electric Chain Hoist platform

- Full range offering: basic/competitive through advanced/premium
- Shared mechanical platforms,
- Differentiation through controls, digitalization, options and services
- Configurable offering drives economies of scale
- Launched globally



- Launched for EMEA at LogiMat in March (2024)
Available in configurator for June orders



Expanded Light Crane System offering

- Expanded range, options and applications
- Free Standing Systems, increased spans, aluminum
- Ergonomics/manipulators, automation, cartesian robots
- Full range extended to Konecranes utilizing well known KBK brand
- Launched in various markets



Process Cranes

Improving process cranes profitability through productization, commercial and project management excellence

Assembly Duty

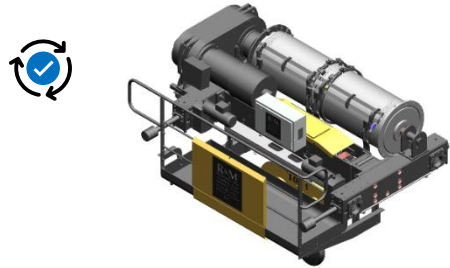

Process Duty



Tailored



A **General**
Demanding applications in general industry, power generation, etc.

B **Industry-specific**
Applications such as WTE, die handling, aviation, paper

C **Tailored**
Applications such as hot metal

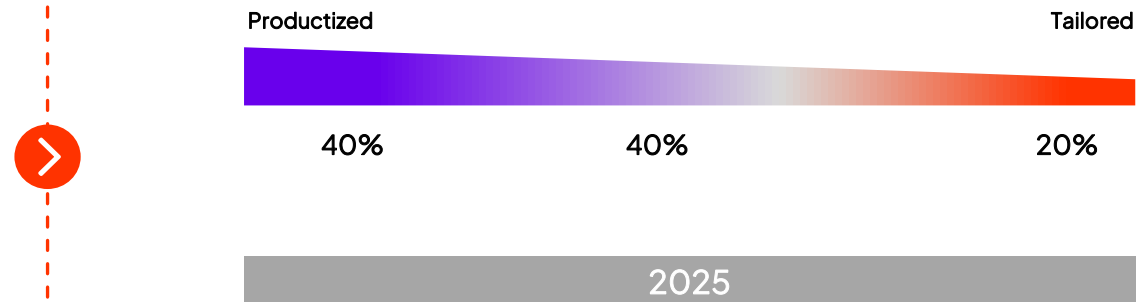
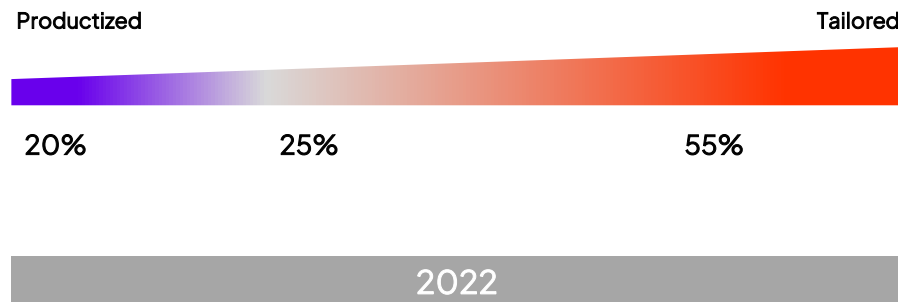

Process cranes provide significant lifecycle management opportunities and are an essential part of the offering as it comes to large customers.

We continue to evaluate our manufacturing footprint to ensure agility and competitiveness in changing environments and conditions

- Crane manufacturing capacity supplemented by subcontracting network
- Component manufacturing centralized in global and regional hubs

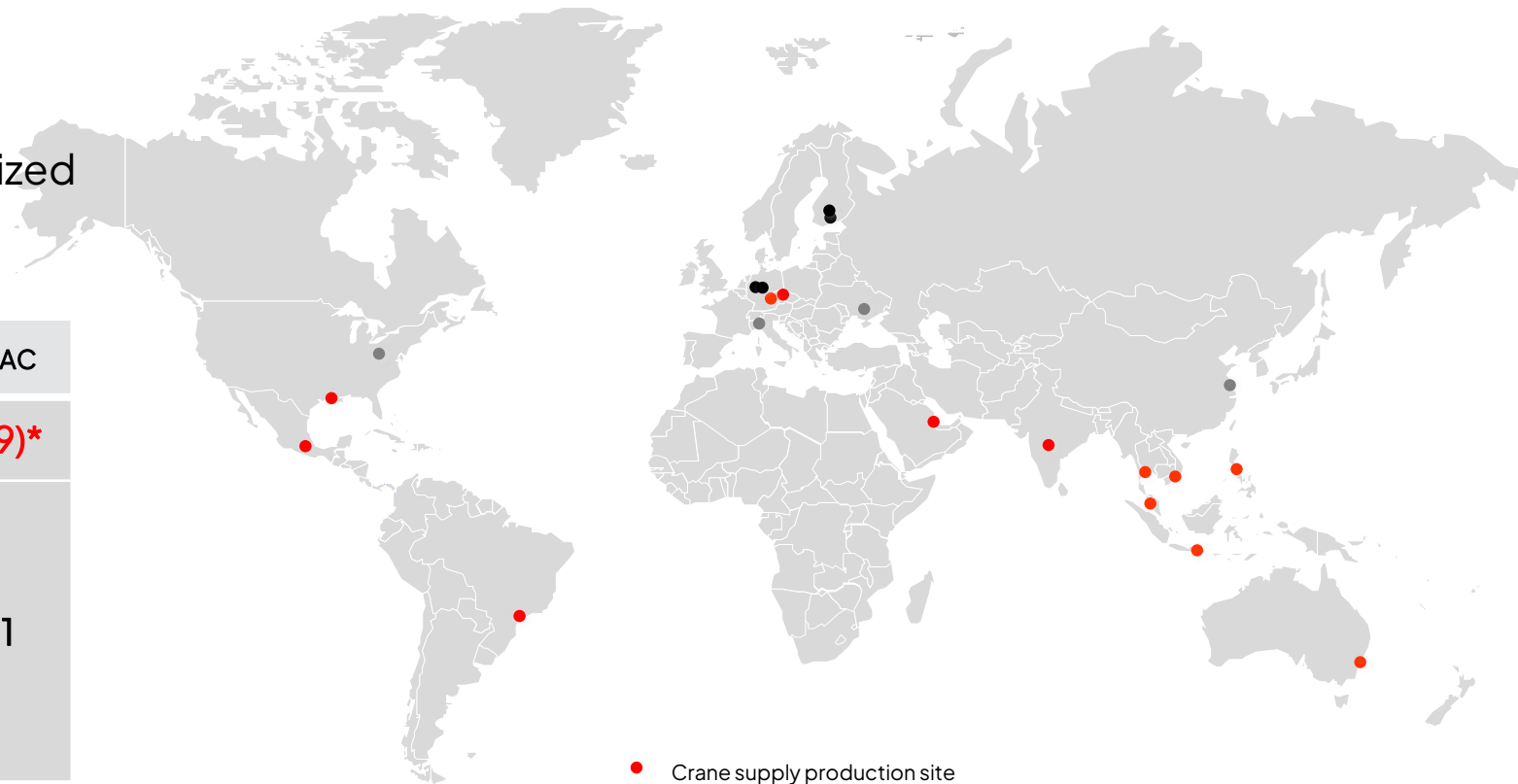

		AME	EMEA	APAC
CRANE SUPPLY		4	4(5)*	8(9)*
COMPONENT SUPPLY	WINCHES		1	
	WIREROPE HOISTS	1	1	1
	LIGHT LIFTING EQUIPMENT		1	

Regional hubs supply multiple products and platforms

Crane factories in US and China are co-located with component factories

⊕ Global hub
⊕ ⊕ Regional hubs

● Crane supply production site
● Component supply production site
● Hybrid crane/component supply production site

*Stopped crane manufacturing in France and Singapore; right-sized India Refocused Wetter, Germany plant; invested in intra-logistics and optimized material flow

5. Business Area overviews

Port Solutions



AGV 558 >

STS 12 >

MAGM Nerval

Solitary

ARMG 37 >

UASC

CMA CGM

HYUNDAI

HYUNDAI

520

535

RWD

RWD

525

528

524

502

526

RWD

RWD

RWD

RWD

Port Solutions in brief

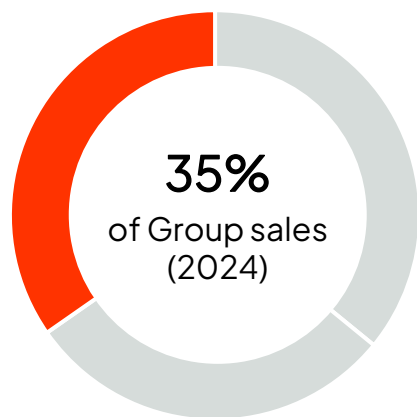

3,392
employees (end of Q1 2025)

1,521.7
net sales, MEUR (2024)

9.3%
comp. EBITA margin (2024)

Key financials, MEUR

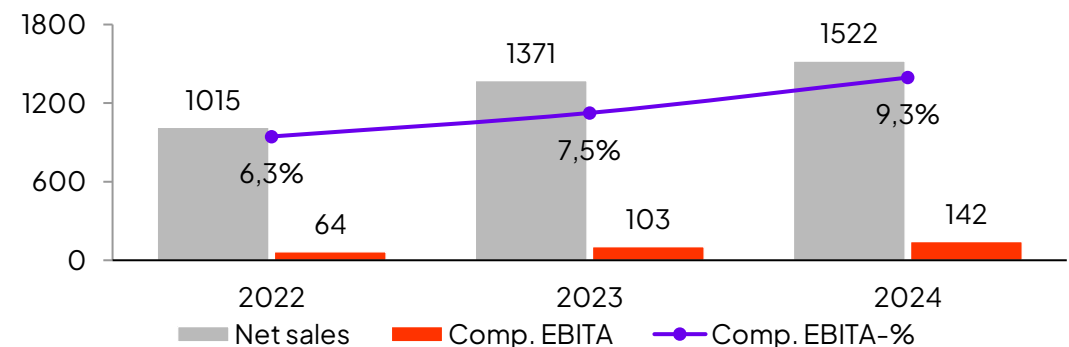

Margin, %





- Konecranes is a market leader in all product categories for ports and container terminals
- Port Solutions offers a full range of manned and fully automated container cranes, mobile harbor cranes, straddle carriers, heavy-duty lift trucks, and automated guided vehicles
- The offering also comprises a complete array of shipyard cranes and Terminal Operating System (TOS) and Equipment Control System (ECS) software, optimizing operations of entire container terminals
- In 2024, the service share of Port Solutions' sales was 18% (278.2 MEUR)

Orders received and order book, MEUR⁽¹⁾

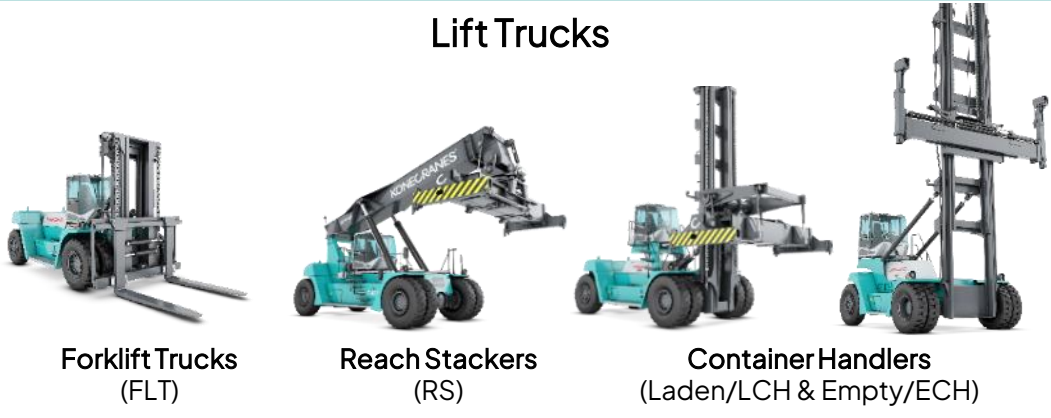

Note (1): Agreement base included in orders received from Q1 2023 onwards and historical figures are restated

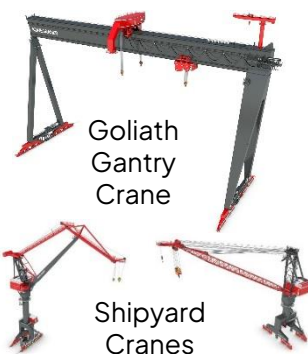
Port Solutions offering – widest and deepest offering for container handling...

<p>Port Services</p>  <p>Service & maintenance, inspections, spare parts, modernizations, retrofits, training, digital services</p>	<p>Lift Trucks</p>  <p>Forklift Trucks (FLT) Reach Stackers (RS) Container Handlers (Laden/LCH & Empty/ECH)</p>	<p>Container Handling Equipment</p>  <p>Ship-To-Shore cranes (STS) Mobile Harbour Cranes (MHC)</p>	
<p>Shipyards Cranes</p>  <p>Goliath Gantry Crane Shipyards Cranes</p>	<p>Software</p>  <p>Terminal Operating System, Equipment Control System (TOS, ECS)</p>	<p>Automated equipment</p>  <p>Automated RTG & RMG System (ARTG, ARMG/ASC) AGVs & A-TTs Straddle Carriers (SC) Sprinter Carriers (SPC, A-SPRINTER) Rail Mounted & Rubber Tired Gantry Cranes (RMG, RTG)</p>	

...covering equipment, automation solutions, software & services

PS offering video ▶ [YouTube](#)

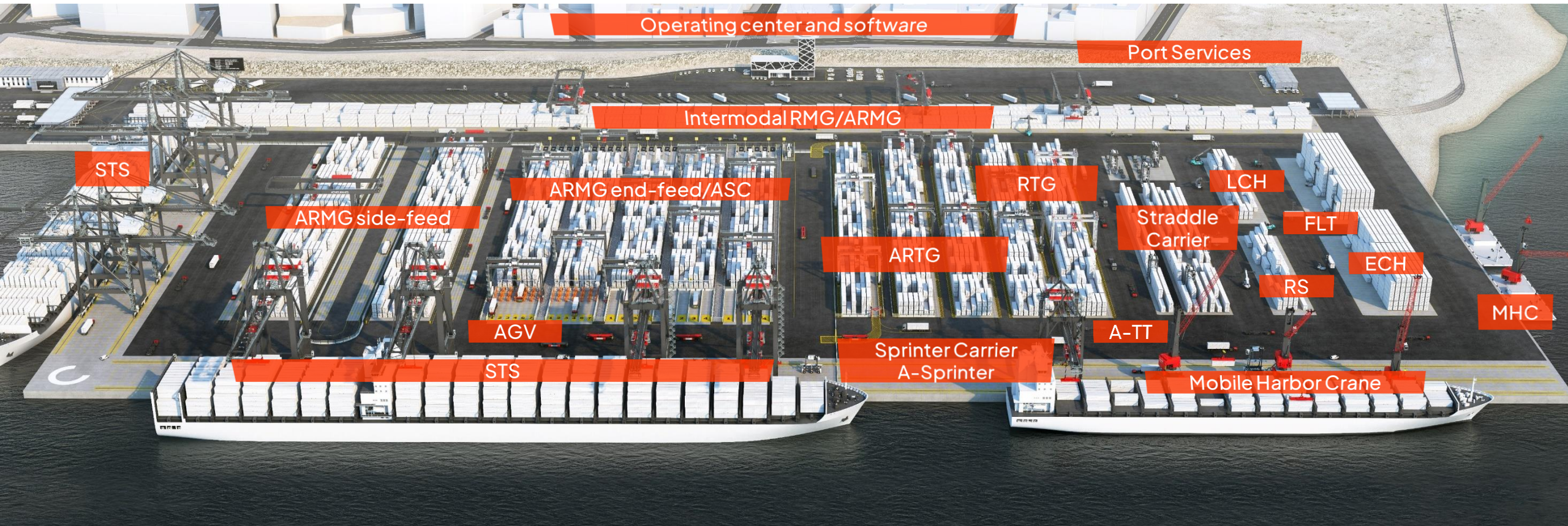

The complete solution for the Path to Port Automation lifting terminals to higher productivity and efficiency

Konecranes Software

In-house software (TOS & ECS)

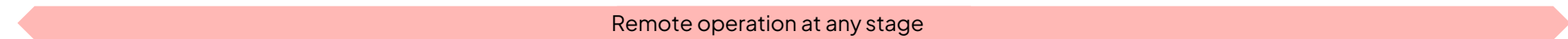

Konecranes Path to Port Automation



Konecranes Equipment

Software agnostic equipment

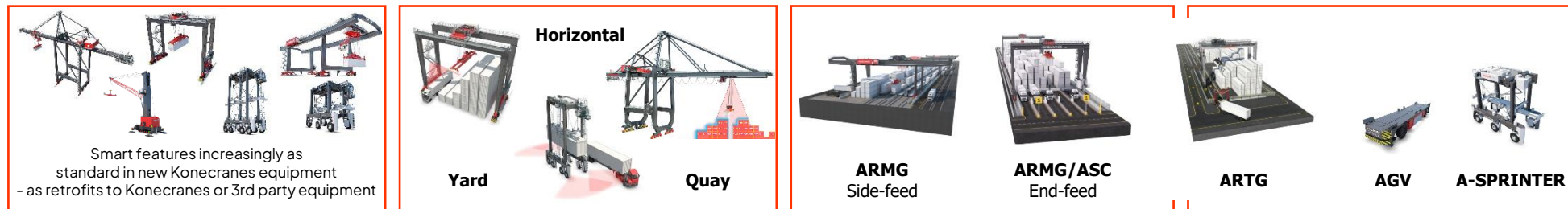

Smart features increasingly as standard in new Konecranes equipment - as retrofits to Konecranes or 3rd party equipment

Konecranes offering

<p>Equipment</p> <ul style="list-style-type: none"> • Full & complementary portfolio with smart features and connectivity for all terminal sizes and stages • Automated & manual options, automation growth path • Container terminal, intermodal, shipyard and bulk 	<p>Services</p> <ul style="list-style-type: none"> • Field service & maintenance, inspections, and spare parts • Digital tools & services, remote monitoring • Modernizations, Retrofits & upgrades (incl. EcoLifting, Automation, remote operations, Smart features) 	<p>Software</p> <ul style="list-style-type: none"> • Improving the operations of ports, terminals and warehouses • Terminal Operating System (TOS), Equipment Control System (ECS), remote operations
--	---	--

A comprehensive fully-electric offering and Path to Ecolifting & retrofits to increase efficiency and lower emissions



Path to Ecolifting & equipment offering		1. Optimized diesel drives	2. Hybrid drives	3. Fully-electric drives
Quayside				
STS				External power
MHC	KONECRANES [®] ecolifting			External power
Containeryard				
RTG	KONECRANES [®] ecolifting			External power/battery
ARTG	KONECRANES [®] ecolifting			External power
RMG				External power
ASC/ARMG				External power
Horizontal transport				
Straddle	KONECRANES [®] ecolifting			Battery
(A)Sprinter	KONECRANES [®] ecolifting			
AGV	KONECRANES [®] ecolifting			Battery
Lift trucks				
Forklift	KONECRANES [®] ecolifting			Battery
RS	KONECRANES [®] ecolifting			
LCH/ECH	KONECRANES [®] ecolifting			

Standard offering
 Feasible to develop

Equipment examples with fully-electric drive (external power supply with direct connection to power grid)



Fully-electric MHC (cable reel)



Fully-electric ASC/ARMG (cable reel)



Fully-electric & Hybrid RTG (busbar)



Fully-electric ARTG (cable reel)



Fully-electric AGV (Li-ion)



Fully-electric E-VER forklift (Li-ion)

Megatrends and other demand drivers providing opportunities for growth

As customers continue to seek increased productivity, enhanced safety and improved predictability



Digitalization
& Automation



eCommerce &
changes in
logistical chains



Sustainability
commitments



Labour shortage



Geopolitics

Equipment market position and development

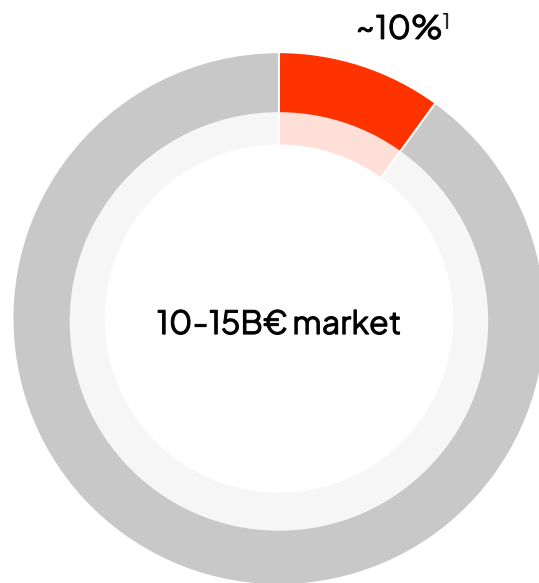

Port Solutions equipment market

Market size/market share includes solutions and equipment. Also segments where Konecranes has no presence.

¹~25% market share in stronghold segments

Market continues to grow

- Global Terminal Operators (GTOs) handle 2/3 of global container throughput and drive the growth
- Consolidation of the customer base continues as GTOs expand their global coverage through M&A and expand to broader logistics chain

Automation opportunity grows

- Pandemic and labour shortage have increased interest towards automation
- Brownfield automation expected to drive future investments
- Growth 2x times faster than manual equipment market

Increased focus on hinterland terminals

- Search for higher efficiencies in end-to-end logistical chains
- Need for added/sustainable capacity

Port Services market position and development

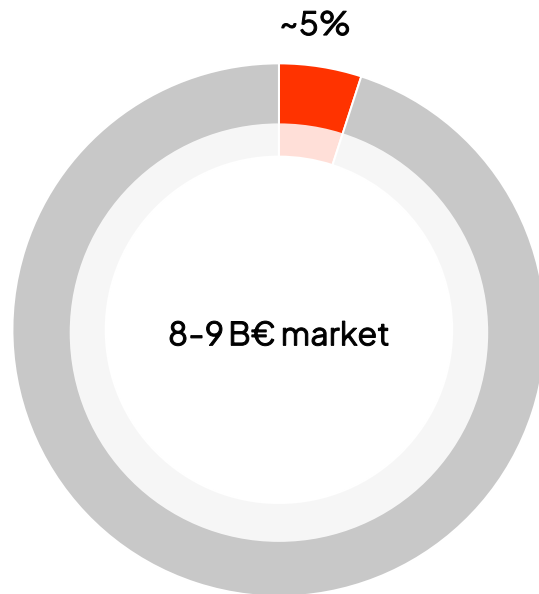

Port Services market expected to grow

- Majority of total market is today in-house/insourced
- Inland terminals more geared for outsourcing than maritime terminals
- Outsourcing driven by aging labour, labour shortage, automation of equipment and systems requiring special knowledge

Data enabled service opportunities

- Data driven predictive maintenance and Service Solutions
- Service Agreements for Automation systems

Port Services market

Market size/market share includes port services (both insourced and outsourced). Services scope based on current Konecranes offering.

We aim to become the World #1 in our core offering

Financial targets:















- Sales growth clearly faster than the market¹
- Comparable EBITA margin of 9-11%²

¹nominal world GDP growth, IMF World Economic Outlook
²as soon as possible, but no later than in 2027. Profitability range, depending on the cycle.

We capture the market opportunity and reach our targets by:

1. Focusing on our core offering with best growth potential
2. Growing our Port Services
3. Further strengthening our automation offering and capturing automation opportunities
4. Strengthening our eco-efficient offering
5. Focusing on Operational Excellence

Market provides plenty of opportunities for growth

	 Service	 AGV	 ASC (ARMG)	 Lift trucks	 Mobile harbor cranes	 (A)RTG cranes	 Straddle carriers
Market size	~8-9 B€ ¹	~0.3 B€	~1.5 B€ ²	~2 B€ ³	~0.6 B€	~1.5 B€ ²	~0.4 B€
Global position	#2	#1-2	#1-2	#2-3	#1-2	#1-2, #1 in ARTG systems	#1-2
Market trend							
Key competitors	In-house Kalmar ZPMC Liebherr ABB, Siemens Local service companies	ZPMC VDL Gaussin	ZPMC Künz Sany HHMC ABB Siemens TMEIC	Kalmar Hyster-Yale Taylor Sany ZPMC	Liebherr Italgru Sennebogen ZPMC Sany	ZPMC Mitsui Liebherr Künz Sany MiJack	Kalmar ZPMC

¹Total market including in-house ²For yard cranes, ASC and RTG combined

³Container handling equipment and medium and heavy forklift trucks

We focus on products with the best growth potential

With the rest of the product portfolio, our focus is on market share and profitability

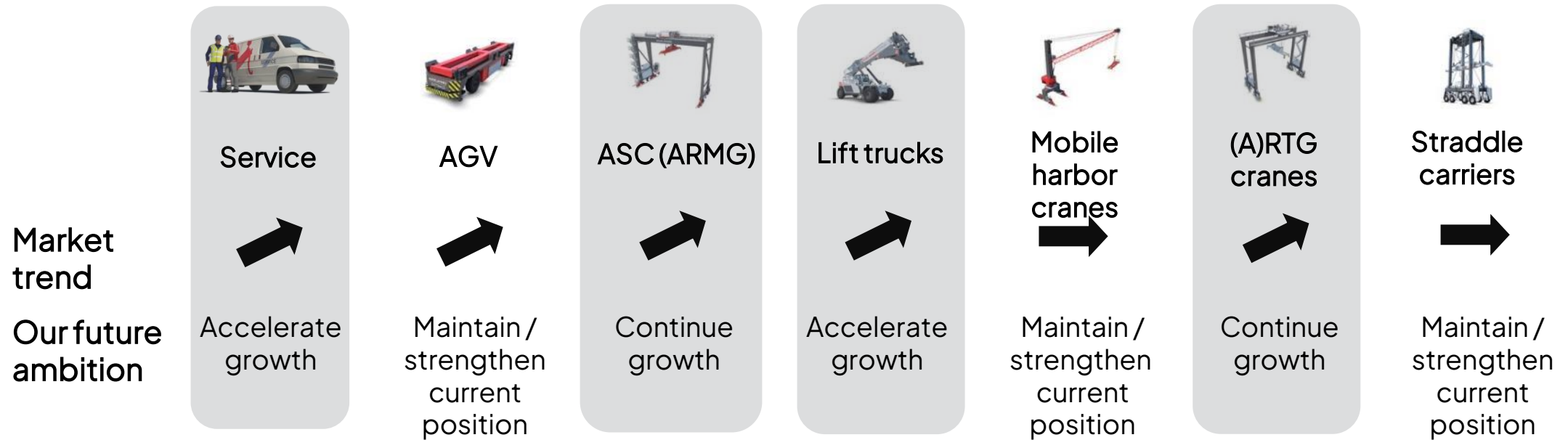

- Focus on products where we offer safety, sustainable solutions, high productivity, high quality, reliability & high uptime and low total cost of ownership (TCO)
- Potential to leverage Konecranes' unique Service offering to customers
- Electrification and agile distribution model provides further opportunities to mobile equipment

We aim to grow Port Services faster than equipment over the cycle

Increasing own and 3rd party fleet

Boosting eCommerce & digital channels

Geographic footprint expansion

KONECRANES PORT SERVICES FACTS

22%

Share of sales

23

countries with own operations

Vast network of service partners and LFT distributors

Data enabled advanced offering and digital services

Sustainability & automation retrofits

Bolt-on M&A

We are leading port automation

65% of all the world's automated container terminals run with Konecranes and more in delivery

Inventor of
AGV
+700 units



Largest western
ASC/ARMG
+400 units



Best performing
ECS
+10 sites



Pioneer of
ARTG
+200 units



We capture automation opportunities in all terminals with our widest and deepest offering

LARGE AUTOMATED CONTAINER TERMINALS

AGV, ASC/ARMG, A-Sprinter and ECS

MEDIUM-SIZED CONTAINER TERMINALS

With our ARTGs and ECS

SMALL-SIZED CONTAINER TERMINALS

Limited automation opportunities

EXISTING SITES WITH EXPANSIONS AND REPLACEMENTS

AGV, ASC/ARMG and ECS

INLAND TERMINALS

ARMG cranes

NEW SERVICE AGREEMENTS

BROWNFIELD CONVERSIONS

From manual SC to ASC/ARMG

Manual RTG to ARTG

OTHER EQUIPMENT BRANDS

With our automation retrofits

6. Appendix

Konecranes at a glance

Key figures, 2024	Konecranes Group	Industrial Service	Industrial Equipment	Port Solutions	Eliminations / Group
Orders received	3,999.6 MEUR	1,559.0 MEUR	1,263.5 MEUR	1,350.5 MEUR	-173.4 MEUR
Orderbook	2,888.4 MEUR	435.9 MEUR	893.3 MEUR	1,559.1 MEUR	
Net sales	4,227.0 MEUR	1,574.7 MEUR	1,289.3 MEUR	1,521.7 MEUR	-158.7 MEUR
Comp. EBITA	551.6 MEUR	331.5 MEUR	116.5 MEUR	142.2 MEUR	-38.5 MEUR
Comp. EBITA-%	13.1%	21.0%	9.0%	9.3%	
Personnel (end of Q1 2025)	16,689	7,963	5,214	3,392	120

Konecranes key financials development

Orders received, MEUR⁽¹⁾

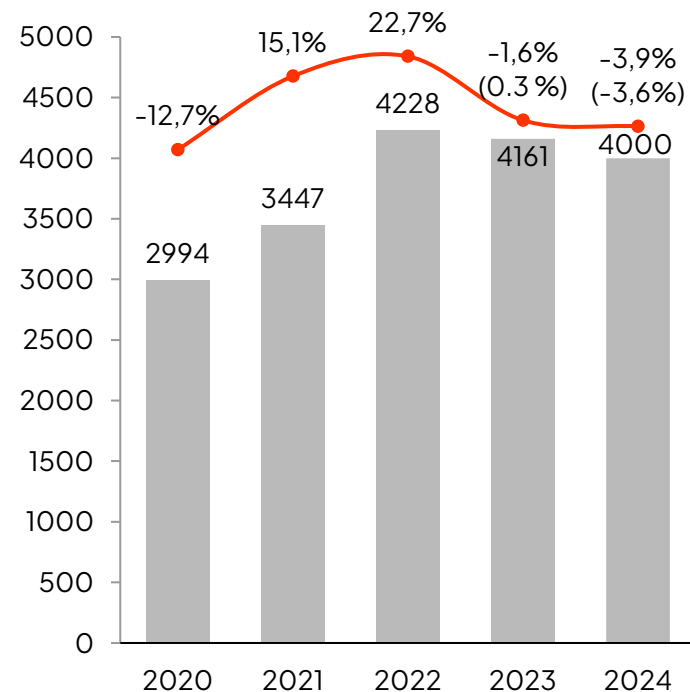

Net sales, MEUR

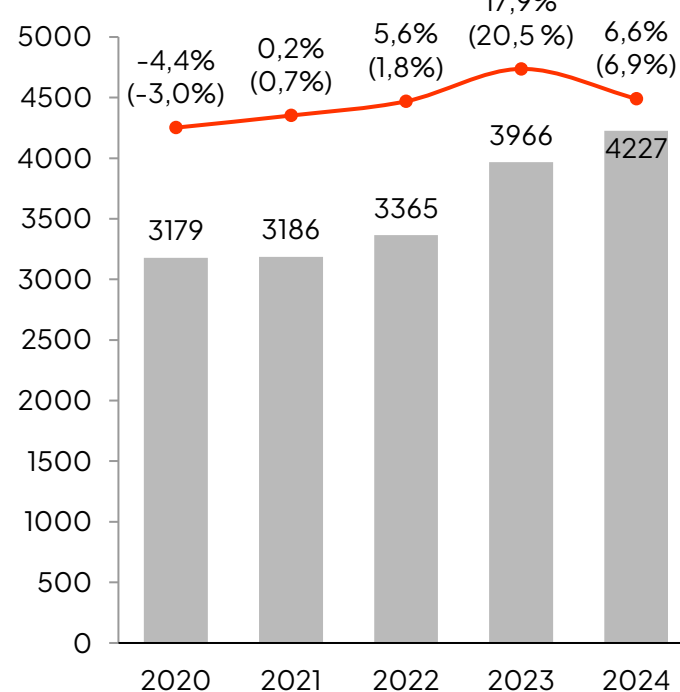

Comp. EBITA, MEUR & comp. EBITA-%

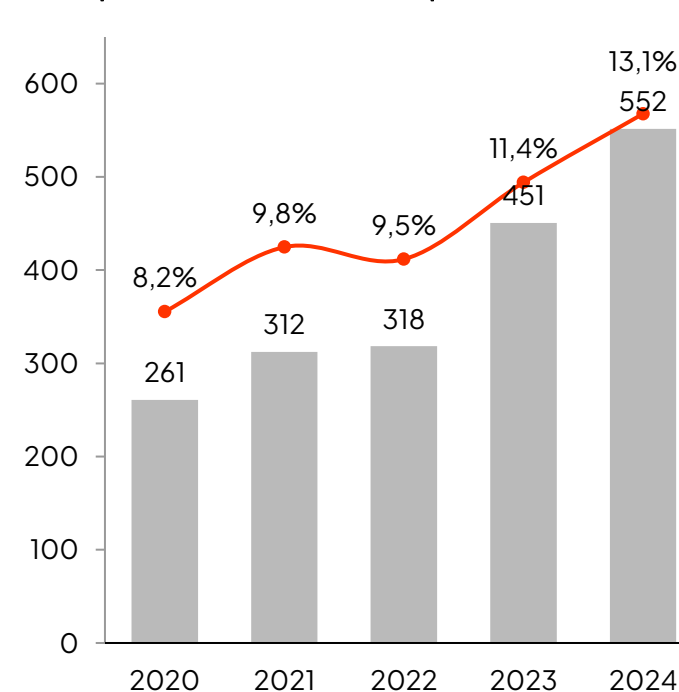

Orders received

Y/Y growth-% (Y/Y growth-% in comparable FX)

Net sales

Y/Y growth-% (Y/Y growth-% in comparable FX)

Comparable EBITA

Comp. EBITA-%

Note (1): Agreement base included in orders received from Q1 2023 onwards and historical figures are restated

Konecranes has a strong eco-efficient equipment offering combined with services to extend product lifecycles

Eco portfolio sales by segment⁽¹⁾⁽²⁾

Circular services	40% 2024	41% 1-3/2025
Industrial Equipment	100% 2024	100% 1-3/2025
Port Solutions	66% 2024	63% 1-3/2025

Eco portfolio⁽¹⁾⁽²⁾

For Industrial Service and Port Service, Konecranes reports circular services revenue that is aligned or eligible with EU taxonomy criteria, share of total group sales. This includes maintenance and repair activities, including modernizations and retrofits as well as spare parts sales.

For Industrial Equipment, Konecranes reports sales of fully electrified equipment, share of total sales.

For Port Solutions, Konecranes reports sales of fully electrified and hybrid equipment, share of total equipment sales.

Note (1): Konecranes has made changes to reporting its eco portfolio. Previous eco portfolio definition included fully electrified and hybrid equipment and modernizations and retrofits, share of total sales.

Note (2): For Port Solutions, the eco portfolio share is impacted by sales mix and timing of project revenues

Konecranes Board of Directors

Pasi Laine

Chair of the Board



Pauli Anttila

Member of the Board



Ulf Liljedahl

Member of the Board



Gun Nilsson

Member of the Board



Päivi Rekonen

Member of the Board



Thomas Schulz

Member of the Board



Birgit Seeger

Member of the Board



Sami Piittisjärvi

Member of the Board



Konecranes Board of Directors

8

Board members

75%

Independent

38%

women

Audit & HR

Committees

Board independence

- All Board members with the exception of Pauli Anttila are deemed to be independent of the Company's significant shareholders
- Pauli Anttila is deemed not to be independent of a significant shareholder of the Company, as he acts as Solidium's Advisor.
- All Board members with the exception of Sami Piittisjärvi are deemed to be independent of the Company
- Sami Piittisjärvi is deemed not to be independent of the Company due to his current position as an employee of Konecranes

Konecranes Leadership Team

Anders Svensson

President and CEO



Teo Ottola

CFO,
Deputy CEO



Fabio Fiorino

Business Area President,
Industrial Service



Tomas Myntti

Business Area President,
Port Solutions



Marko Tulokas

Business Area President,
Industrial Equipment



Minna Aila

Executive Vice President, Corporate
Affairs & Brand⁽¹⁾



Claes Erixon

Executive Vice President,
Technologies⁽³⁾



Christine George

Executive Vice President,
Strategy & Business Development⁽²⁾



Anneli Karkovirta

Executive Vice President,
People and Culture



Sirpa Poitsalo

Executive Vice President,
General Counsel



10
Konecranes
Leadership
Team members

40%
women

4
different
nationalities

We have a strong balance sheet with financial flexibility

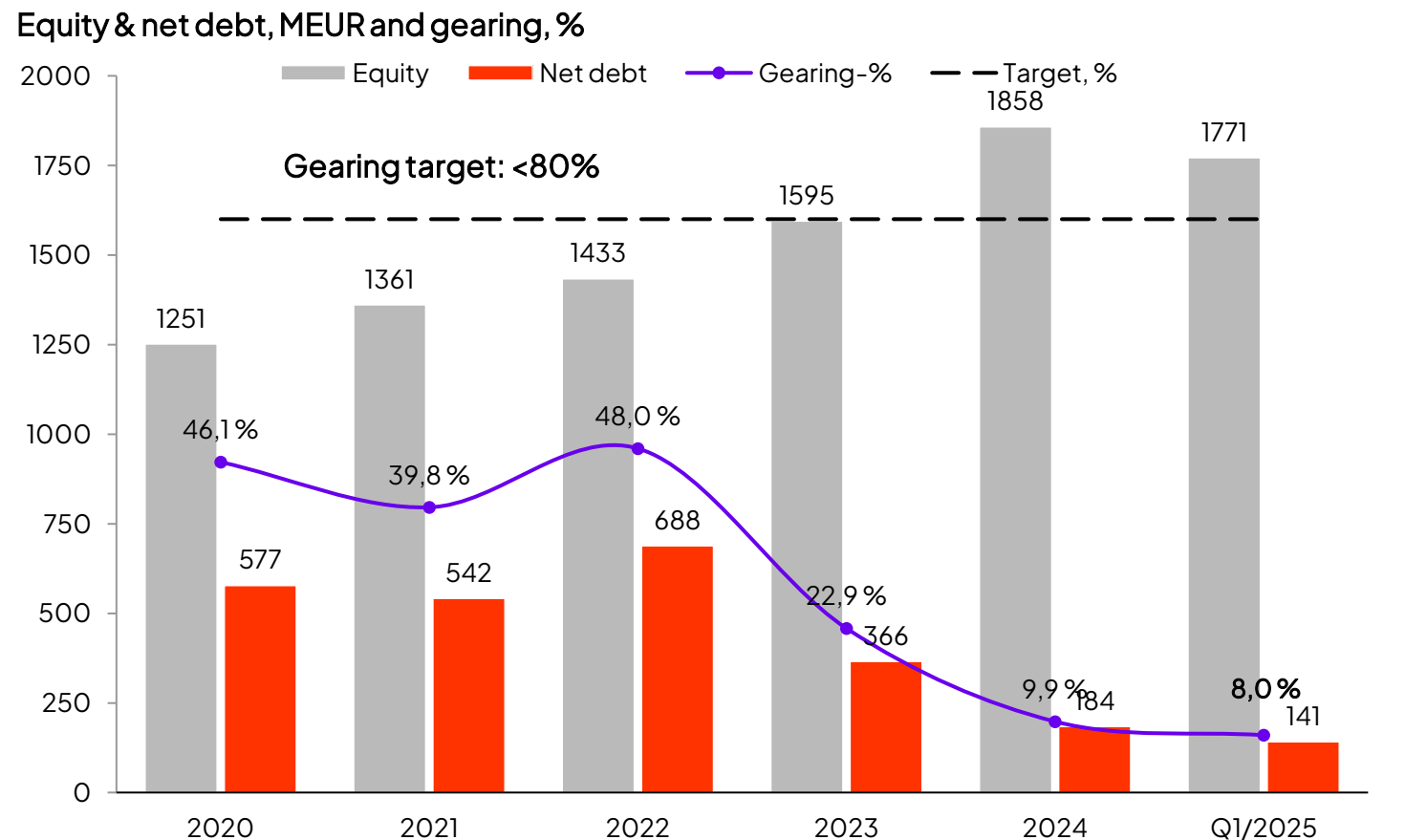

Group interest-bearing liabilities and net debt

Structure and maturity profile of interest-bearing liabilities (Dec 31, 2023)

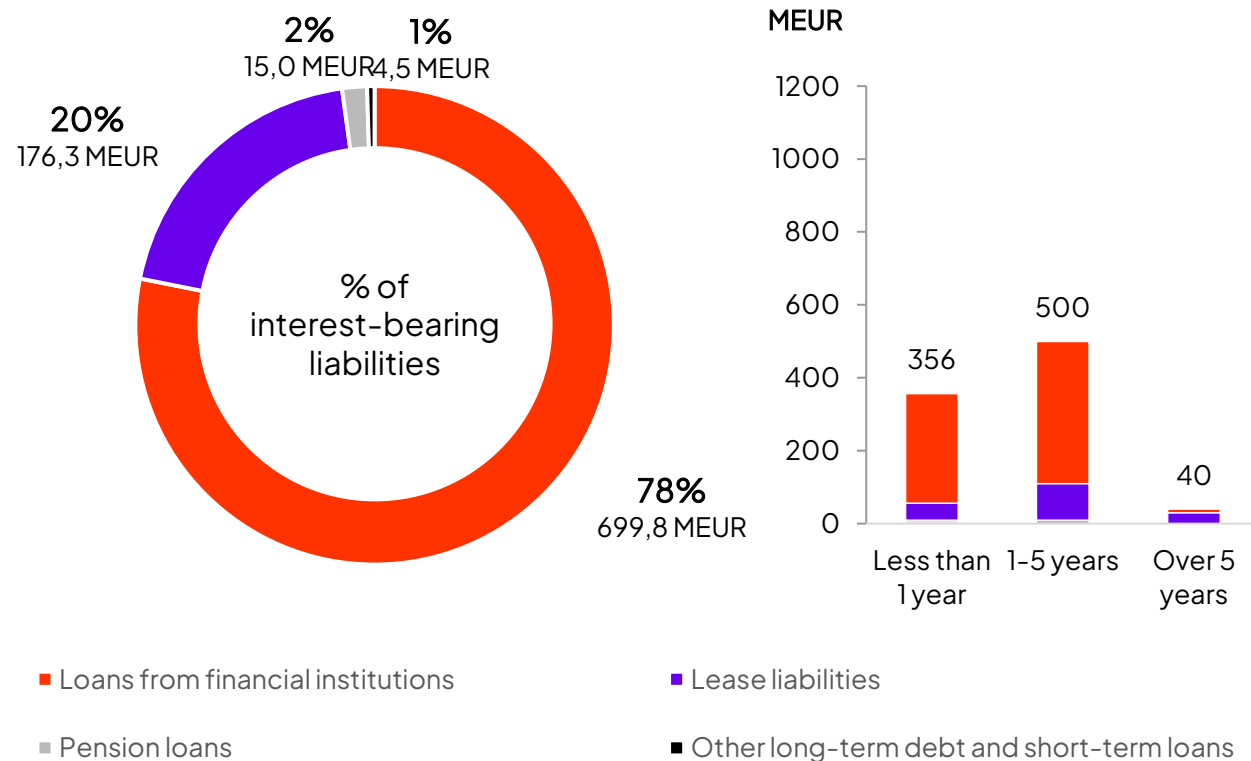

Interest-bearing net debt (Dec 31, 2024)

EUR million	31 Dec 2024	31 Dec 2023
Non current interest bearing liabilities	539.3	727.7
Current interest bearing liabilities	356.3	227.2
Interest-bearing liabilities	895.6	954.9
Loans receivable	-2.1	-2.5
Cash and cash equivalents	-710.0	-586.6
Interest-bearing net debt	183.5	365.8

Capital expenditure, depreciation and R&D expenditure

Capital expenditure and depreciation, MEUR

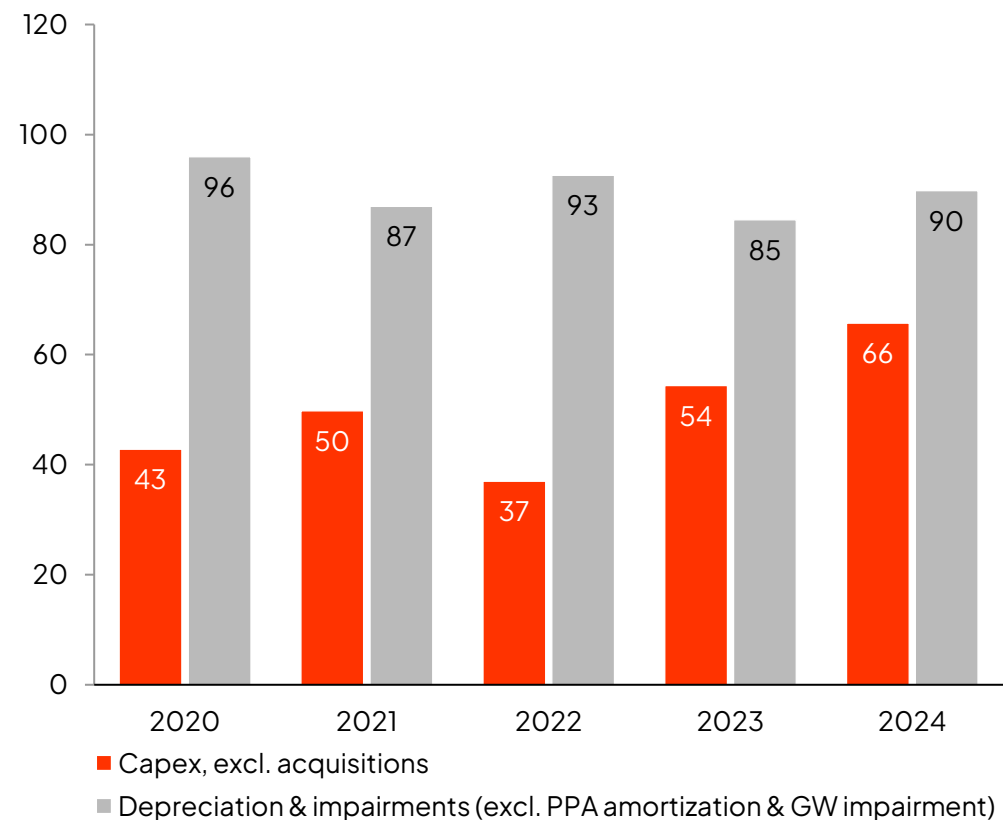

Research and development, MEUR and percentage of sales

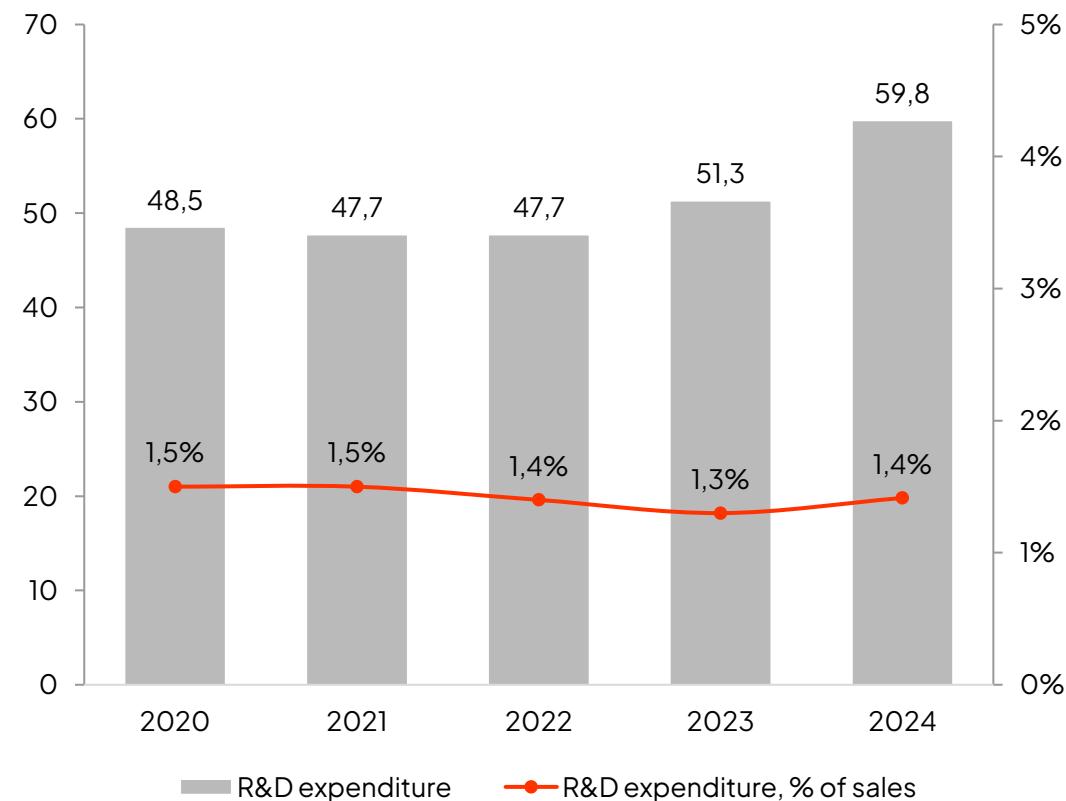

Our net working capital development is driven by timing of projects and delivery capability

Net working capital, MEUR and percentage of sales⁽¹⁾

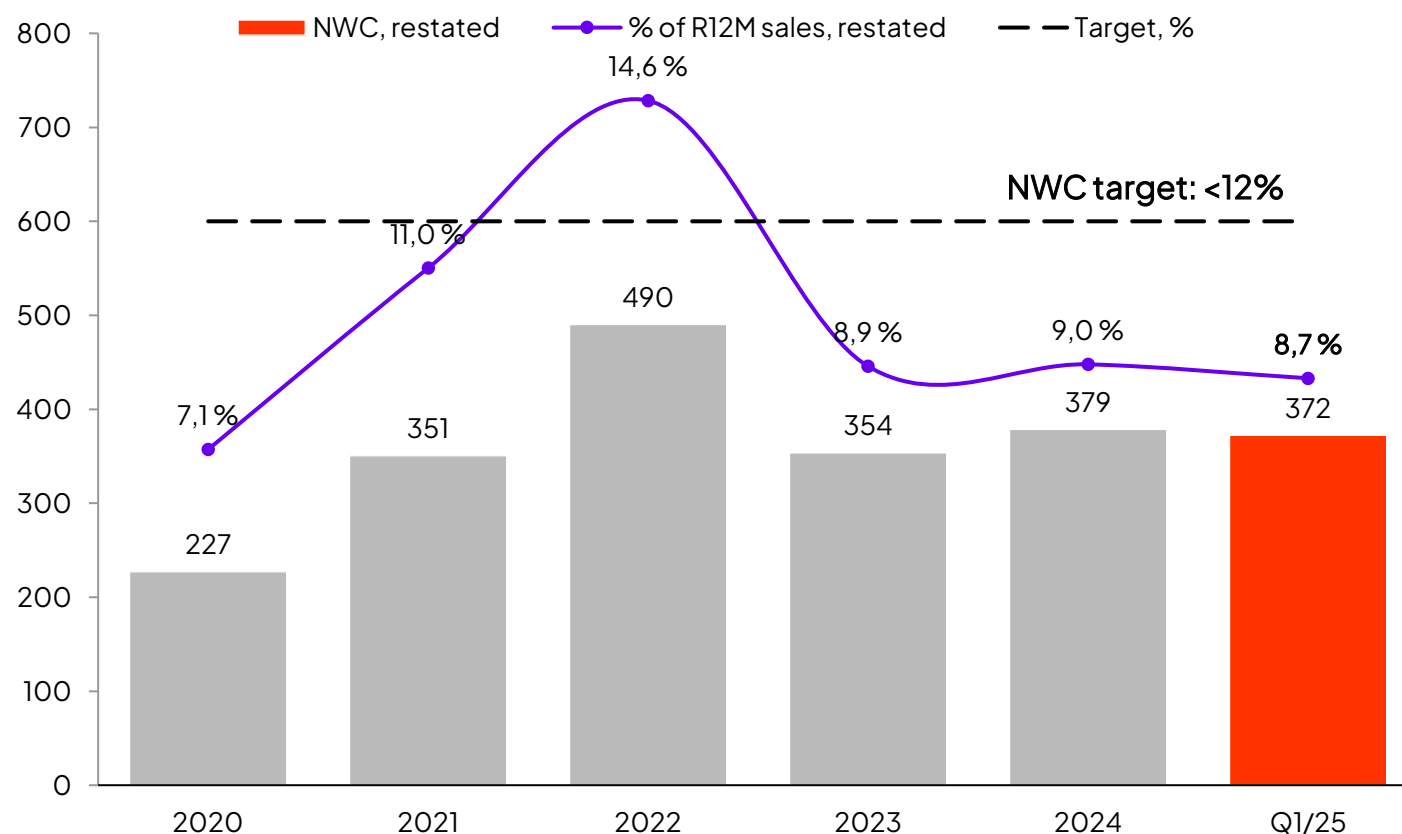

Note (1): NWC formula changed from Q1 2023 onwards and net working capital for historical periods restated
 Note (2): Q1/25 excluding dividend payable of EUR 130.7 million, Q1/24 excluding dividend payable of EUR 106.9 million

Free cash flow and return on capital employed

Free cash flow, MEUR

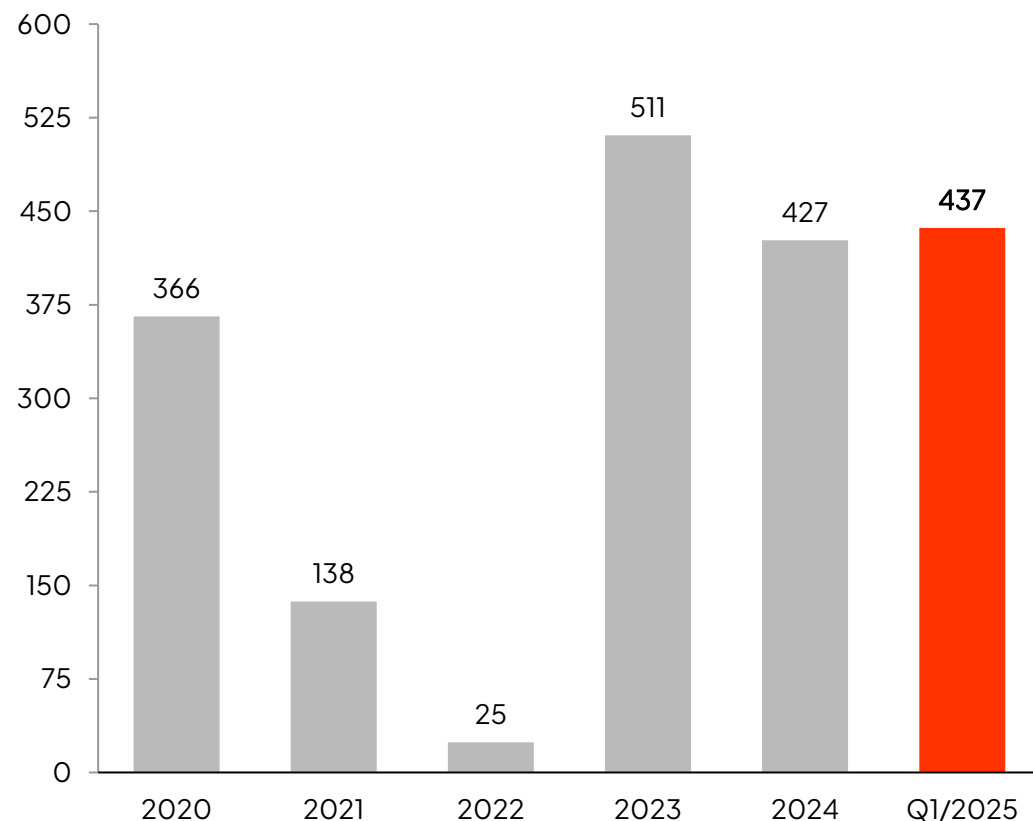

Capital employed, MEUR and comp. return on capital employed, %

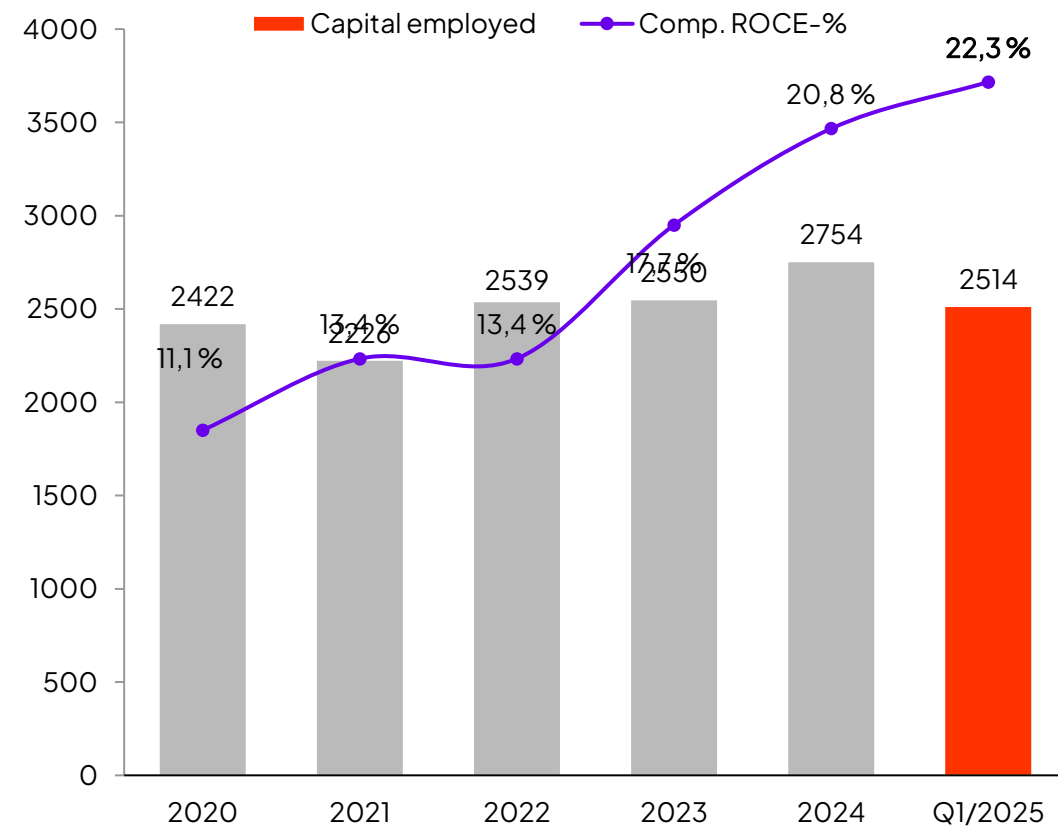

Operating expenses

EUR million	1-12/ 2022	1-12/ 2023	1-12/ 2024
Change in work in progress	-170.9	13.4	14.4
Production for own use	-1.1	-0.7	-0.3
Material and supplies	1,267.5	1,303.7	1,382.7
Subcontracting	414.7	503.9	481.5
Materials, supplies and subcontracting	1,510.2	1,820.3	1,878.2
Wages and salaries	884.8	959.2	1,025.2
Pension costs	66.9	76.9	85.0
Other personnel expenses	140.2	150.5	153.8
Personnel cost	1,091.9	1,186.6	1,264.0
Other operating expenses	423.3	451.5	463.4
Total operating expenses	3,025.3	3,458.4	3,605.6

Operating expenses, MEUR and operating expenses, % of sales

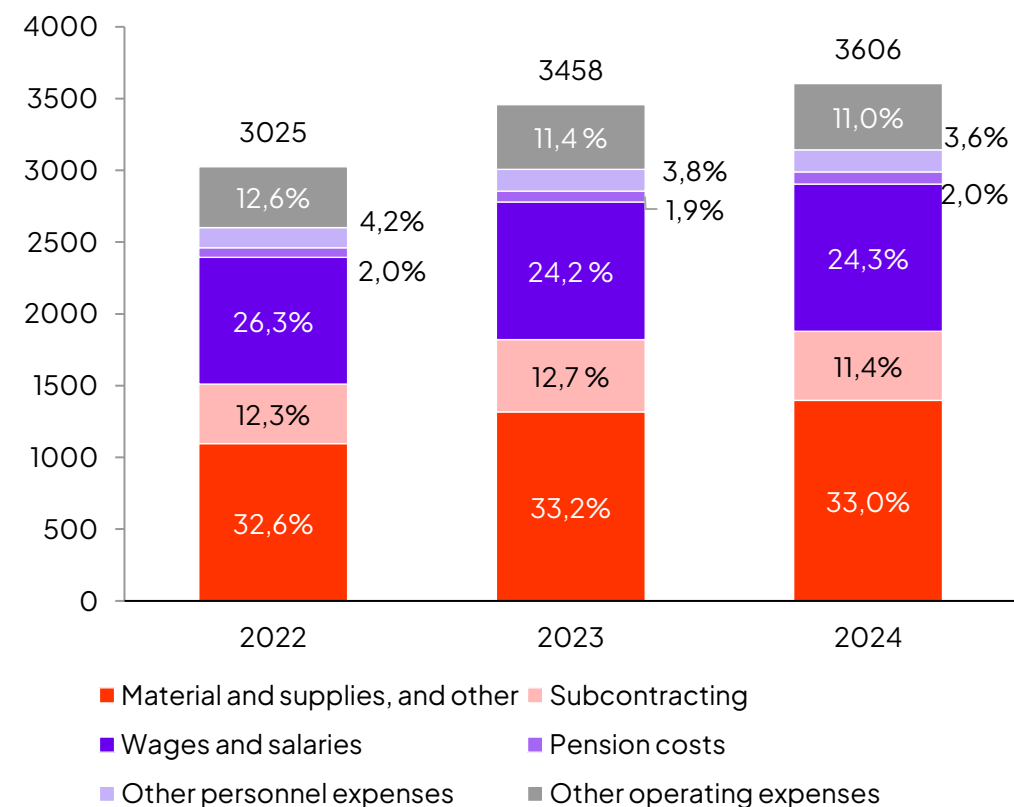

Dividend per share and pay-out ratio development

Dividend per share, EUR and dividend/earnings ratio, %

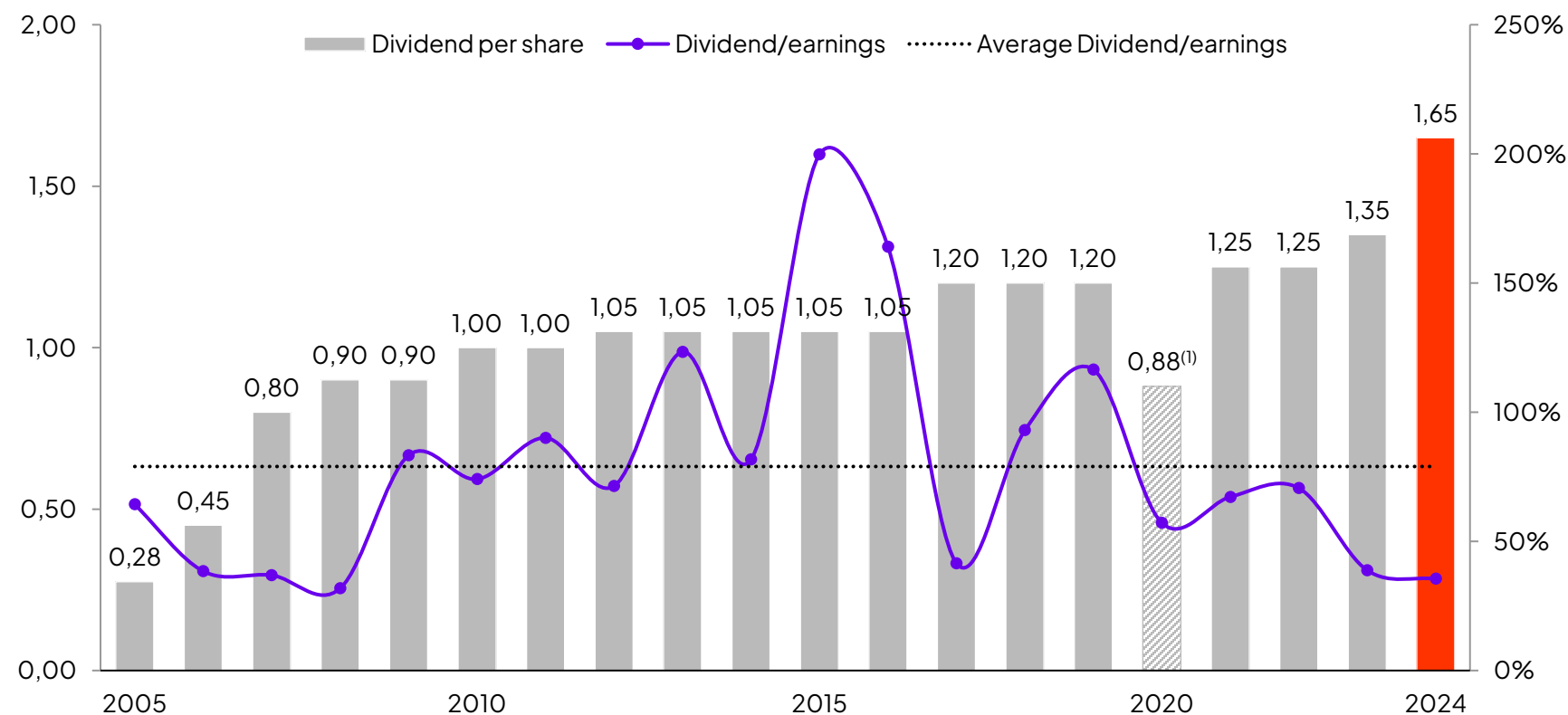

1.65 EUR

Dividend for 2024

79%

average dividend pay-out ratio for 2005-2024

4.0%

average effective dividend yield for 2005-2024

Konecranes aims to pay a stable to increasing dividend per share, over the cycle

Note (1): For 2020, the dividend was in accordance with the Combination Agreement, the planned merger with Cargotec was cancelled in Mar-2022

Major shareholders and distribution of ownership

Ownership structure (as at Mar 31, 2024)

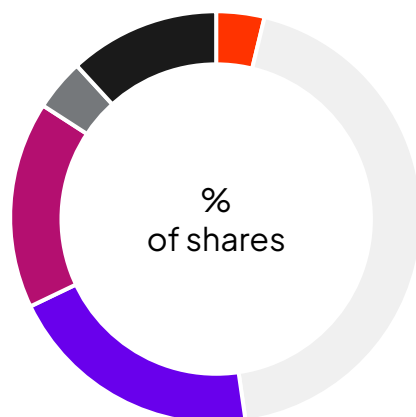

- Private companies (3,8% of shares)
- Financial and insurance corporations (43,9% of shares)
- Public sector organizations (20,2% of shares)
- Households (16,2% of shares)
- Non-profit organizations (4,1% of shares)
- Foreigners (11,8% of shares)

45,221 shareholders (42,061 households)

Major shareholders (as at Mar 31, 2025)

Shareholder	# of shares	Shares, %
1 Solidium Oy	8,793,123	11.10
2 Varma Mutual Pension Insurance Company	2,592,201	3.21
3 Gustavson Stig and family ⁽¹⁾	2,366,157	2.99
4 Ilmarinen Mutual Pension Insurance Company	2,327,049	2.94
5 Elo Mutual Pension Insurance Company	1,229,000	1.55
6 Oras Invest Ltd	1,129,000	1.43
7 OP Investment Funds	960,512	1.21
8 The State Pension Fund	730,000	0.92
9 Nordea Funds (Finland)	690,088	0.87
10 Samfundet folkhälsan i Svenska Finland rf	615,600	0.78
Top 10 total	19,105,681	24.12
Nominee registered	38,877,939	49.07
Other shareholders	21,238,286	26.81
Total number of shares outstanding	79,221,906	100.00

Note (1): Includes shares held by Stig Gustavson and the retained voting rights of shares donated to near relatives

7. Latest quarterly result presentation



April 24, 2025

Q1 2025 Report

Anders Svensson, President and CEO
Teo Ottola, CFO

KONECRANES

Important Notice

The following applies to this presentation, the oral presentation of the information in this presentation by Konecranes Abp (the “Company” or “Konecranes”) or any person on behalf of the Company, and any question-and-answer session that follows the oral presentation (collectively, the “Information”). In accessing the Information, you agree to be bound by the following terms and conditions.

This presentation does not constitute an offer of or an invitation by or on behalf of, Konecranes, or any other person, to purchase any securities.

The Information is not directed to, or intended for distribution to or use by, any person or entity that is a citizen or resident of, or located in, any locality, state, country or other jurisdiction where such distribution or use would be contrary to law or regulation or which would require any registration or licensing within such jurisdiction.

The Information contains forward-looking statements. All statements other than statements of historical fact included in the Information are forward-looking statements. Forward-looking statements give the Company’s current expectations and projections relating to its financial condition, results of operations, plans, objectives, future performance and business. These statements may include, without limitation, any statements preceded by, followed by or including words such as “target,” “believe,” “expect,” “aim,” “intend,” “may,” “anticipate,” “estimate,” “plan,” “project,” “will,” “can have,” “likely,” “should,” “would,” “could” and other words and terms of similar meaning or the negative thereof. Such forward-looking statements involve known and unknown risks, uncertainties and other important factors beyond the Company’s control that could cause the Company’s actual results, performance or achievements to be materially different from the expected results, performance or achievements expressed or implied by such forward-looking statements. Such forward-looking statements are based on numerous assumptions regarding the Company’s present and future business strategies and the environment in which it will operate in the future.

The Information, including but not limited to forward-looking statements, applies only as of the date of this document and is not intended to give any assurances as to future results. Market data used in the Information not attributed to a specific source are estimates of the Company and have not been independently verified.

Agenda



Anders Svensson
President and CEO

1. **Quarter's highlights** p. 4
2. Market environment p. 5
3. Group financial performance p. 7
4. Demand outlook & financial guidance p. 11



Teo Ottola
CFO

5. Group profitability bridge p. 14
6. Business Areas p. 15
7. Net working capital & free cash flow p. 18
8. Gearing & return on capital employed p. 19

Q&A

Q1 2025 – Good start to the year

Demand environment remained good in Q1

- Orders +15.9% Y/Y (comp. FX)
- Y/Y order intake growth in all three Business Areas
- Sales €984 million, +6.9% Y/Y (comp. FX)

Q1 comparable EBITA-% at 11.1%

- Profitability remained the same as a year ago
- Y/Y pricing slightly positive, execution & sales mix weaker
- Profitability improved in Industrial Service and Port Solutions, but decreased in Industrial Equipment

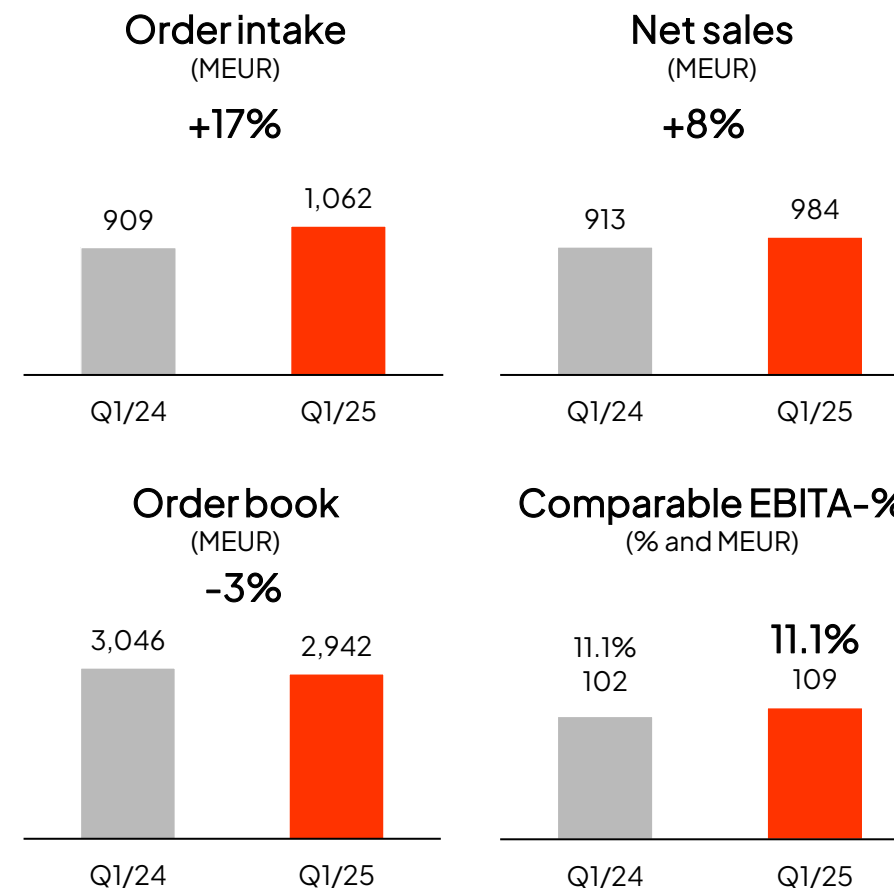

Market environment – Service and Industrial Equipment

EU capacity utilization rate, %

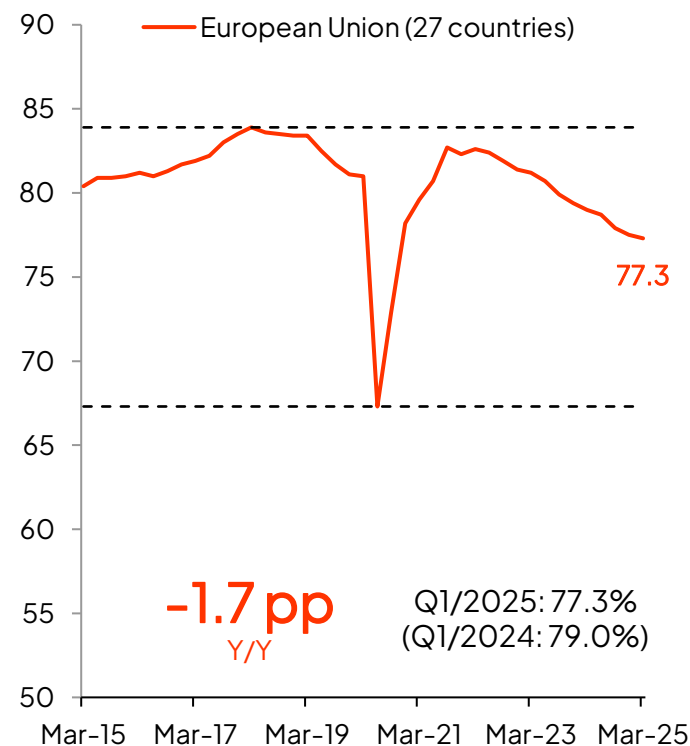

US capacity utilization rate, %

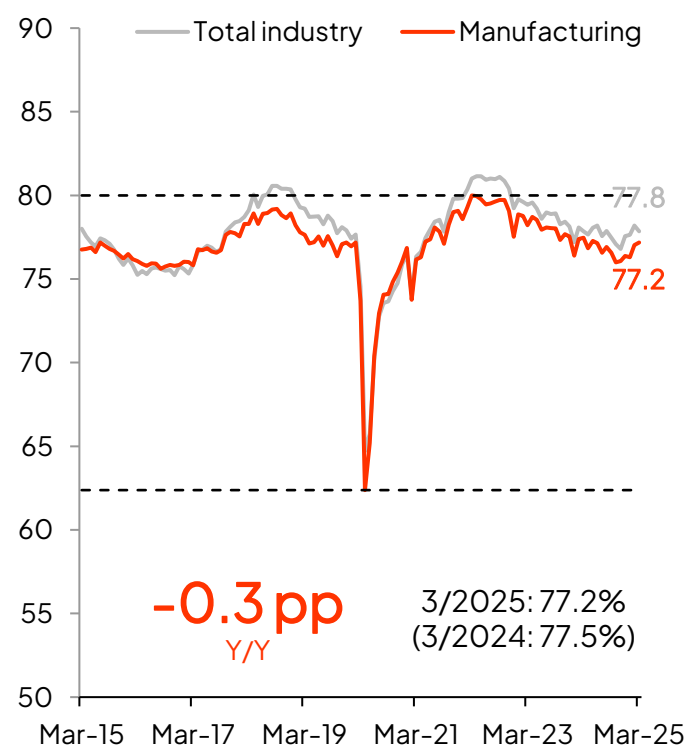

Manufacturing PMIs – Brazil, India & China

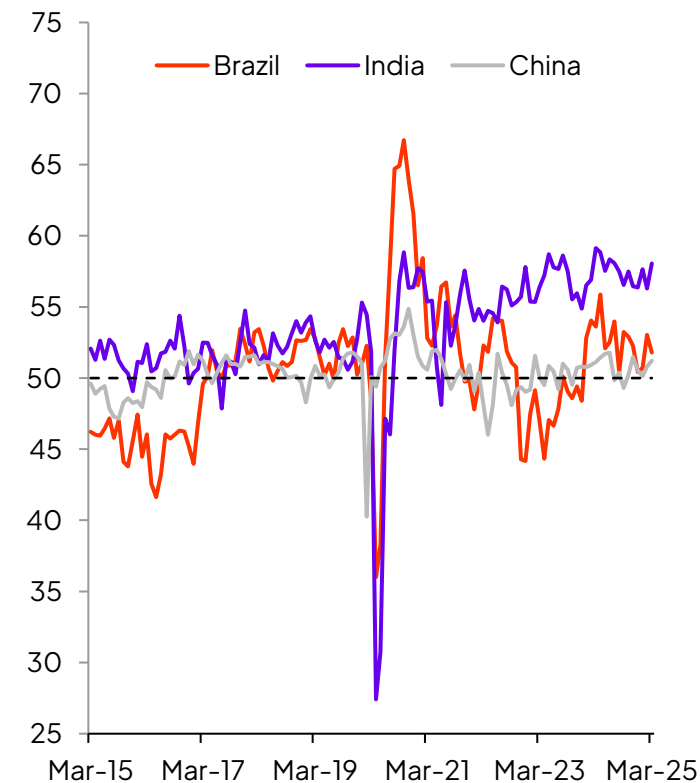

Source: Eurostat, Federal Reserve Economic Data, S&P Global

Market environment – Port Solutions

RWI/ISL Container Throughput Index(2015 = 100)

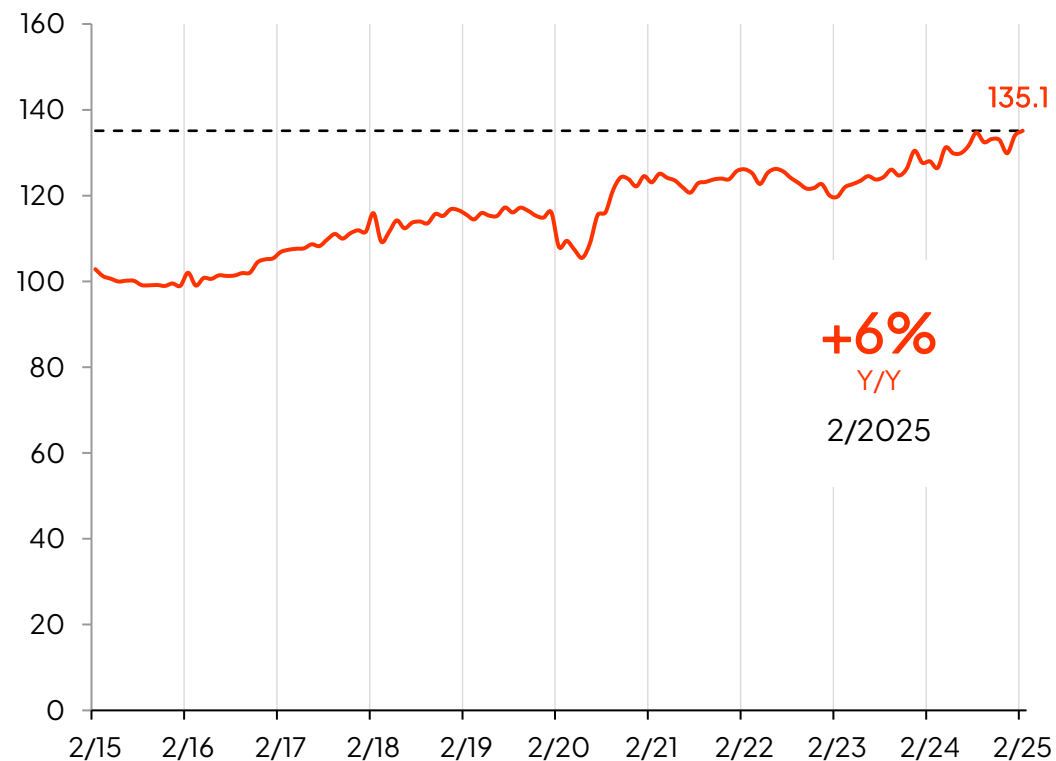

Monthly index change Y/Y, %

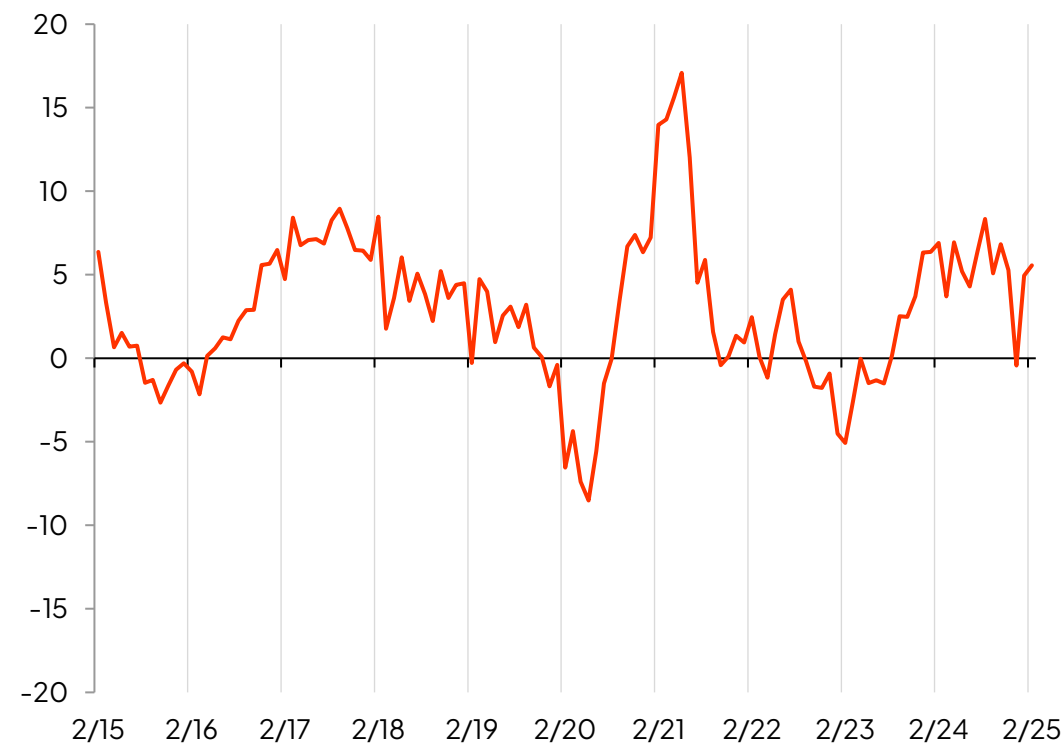

Source: RWI/ISL

Group order intake and net sales

Order intake, MEUR⁽¹⁾

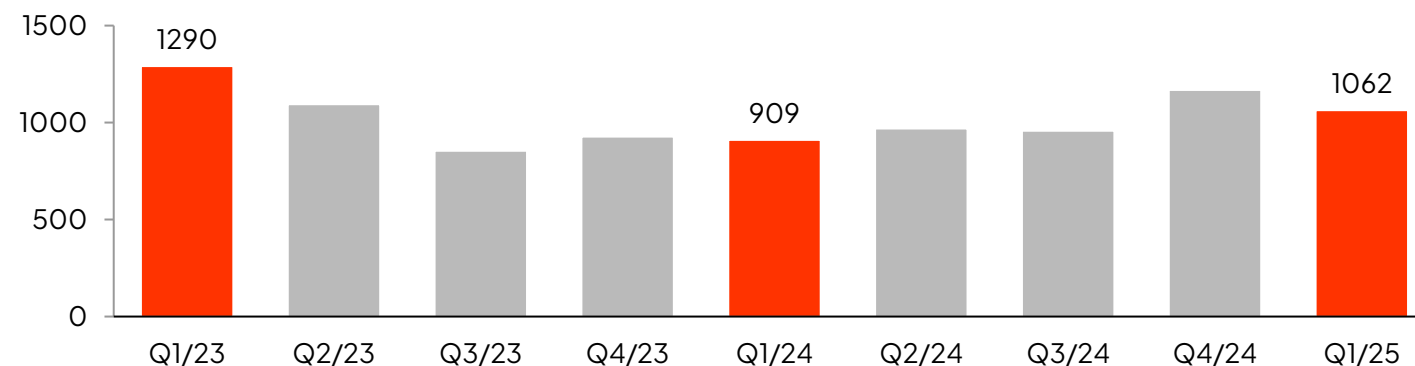

Net sales, MEUR

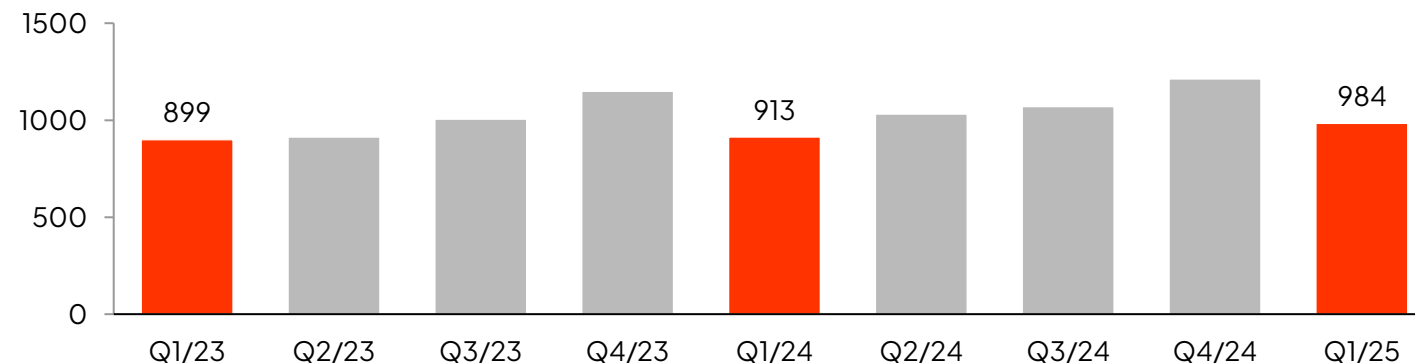

Order intake

+16.8%

Y/Y reported

+15.9%

Y/Y comp. FX

- EUR 1,062.2 million
- Increase in all Business Areas
- Increase in EMEA and the Americas, decrease in APAC

Net sales

+7.7%

Y/Y reported

+6.9%

Y/Y comp. FX

- EUR 983.7 million
- Increase in all Business Areas
- Increase in EMEA, the Americas and APAC

Note (1): Agreement base included in orders received from Q1 2023 onwards and historical figures are restated

Group order book

Orderbook, MEUR

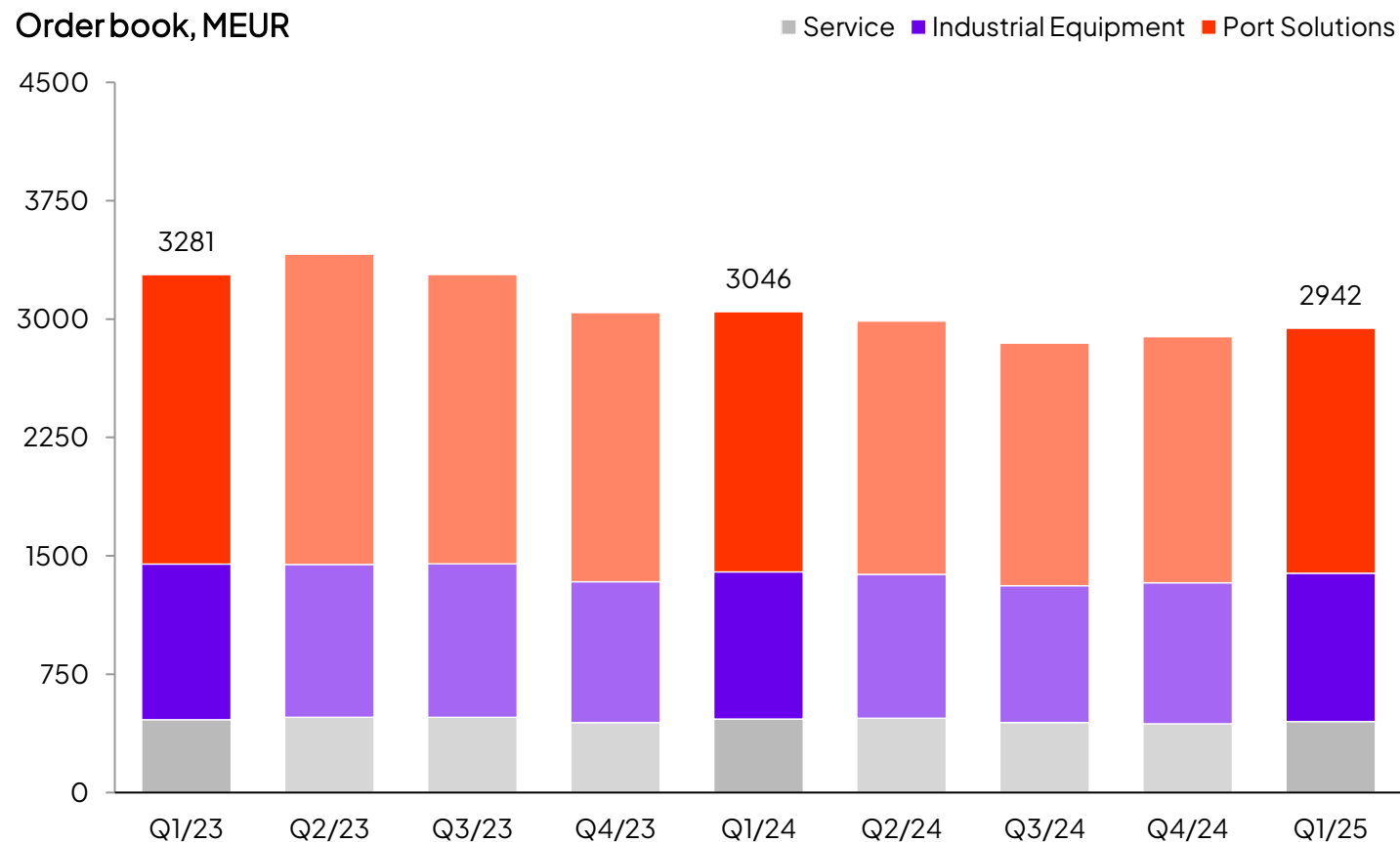

Orderbook

-3.4%

Y/Y reported

-3.5%

Y/Y comp. FX

- EUR 2,941.8 million
- Decrease in Port Solutions and Industrial Service, approximately flat in Industrial Equipment
- Orderbook remains on a good level historically

Group comparable EBITA

Comparable EBITA, MEUR & margin-% ■ Comp. EBITA ● C. EBITA-% — R12M c. EBITA-%

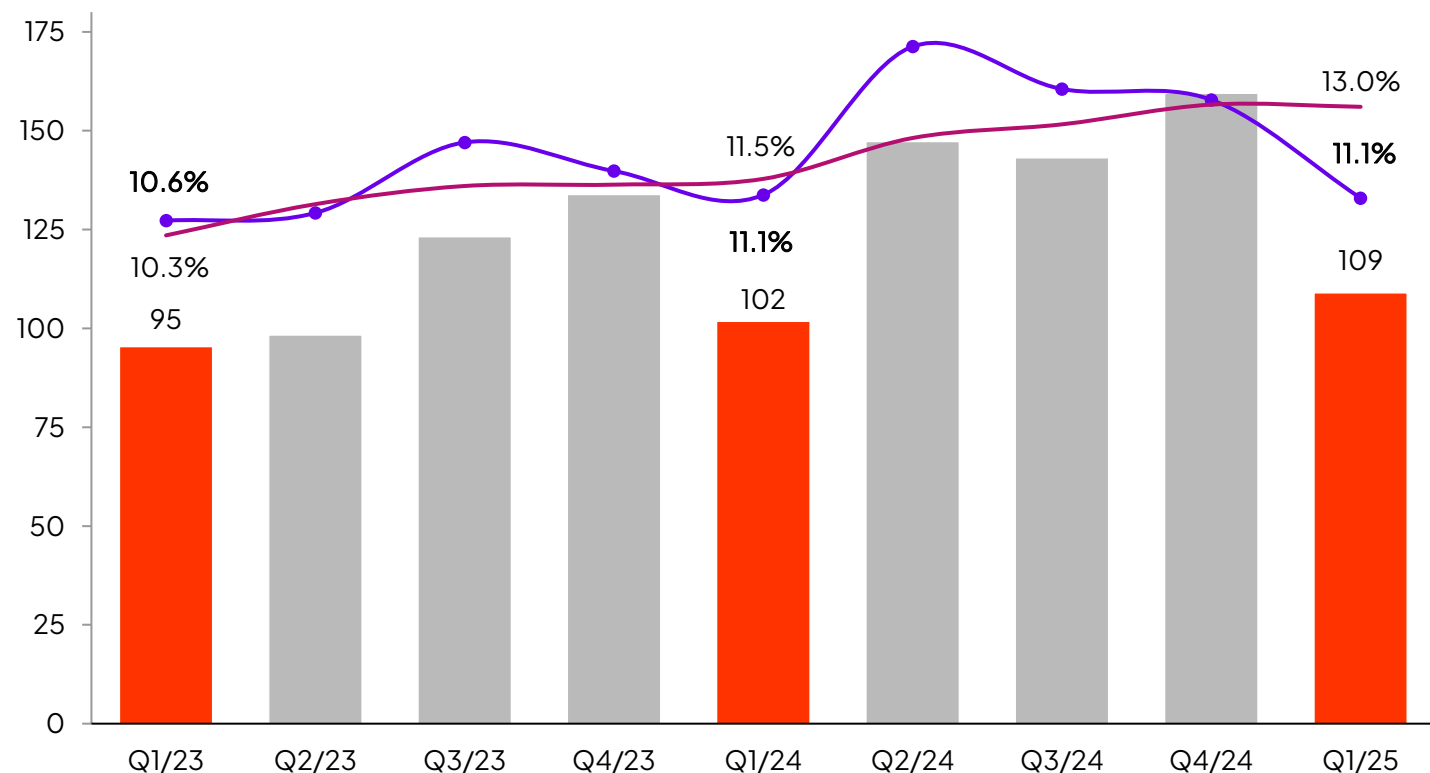

Comparable EBITA

11.1% margin -0.1 pp Y/Y

- EUR 109.0 million
- Comparable EBITA-% increase in Industrial Service and Port Solutions, decrease in Industrial Equipment
- Comparable EBITA-% Y/Y pricing slightly positive, execution & sales mix weaker
- Gross margin decreased year-on-year

Progress towards Konecranes' financial targets

Group

Target: 12-15%⁽¹⁾

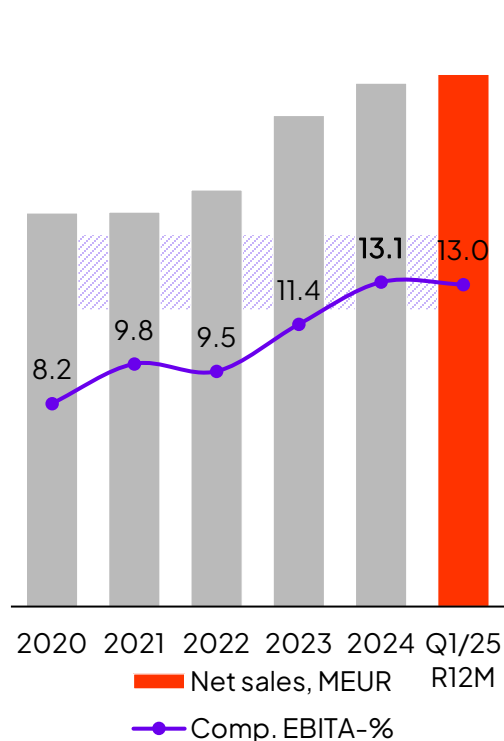

Industrial Service

Target: 20-24%⁽¹⁾

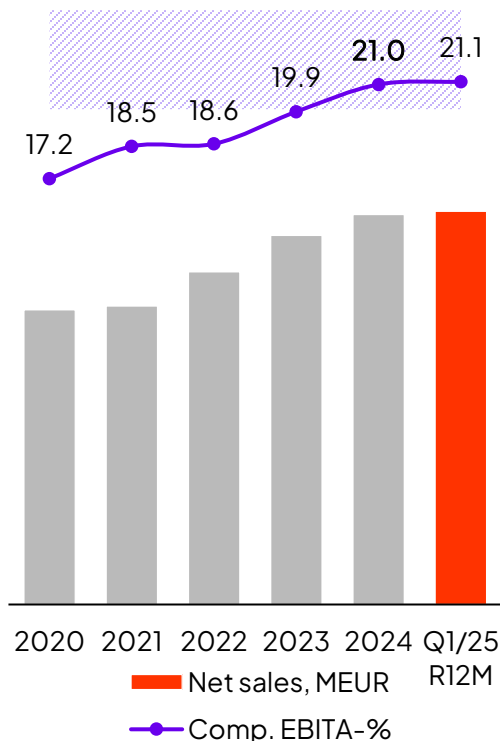

Industrial Equipment

Target: 8-10%⁽¹⁾

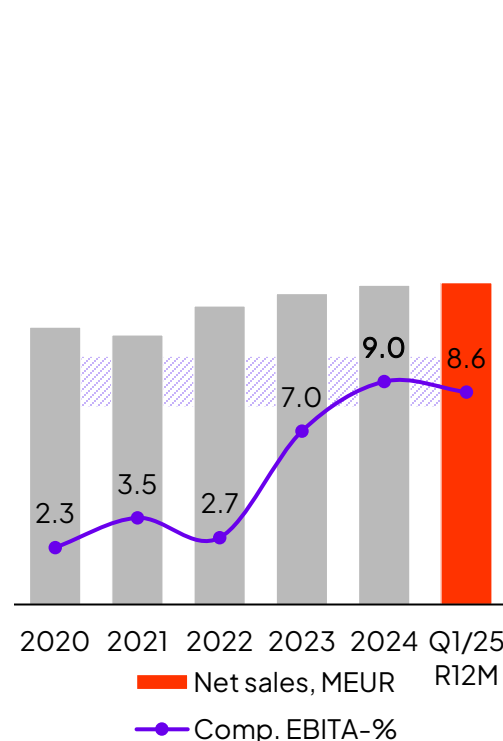

Port Solutions

Target: 9-11%⁽¹⁾

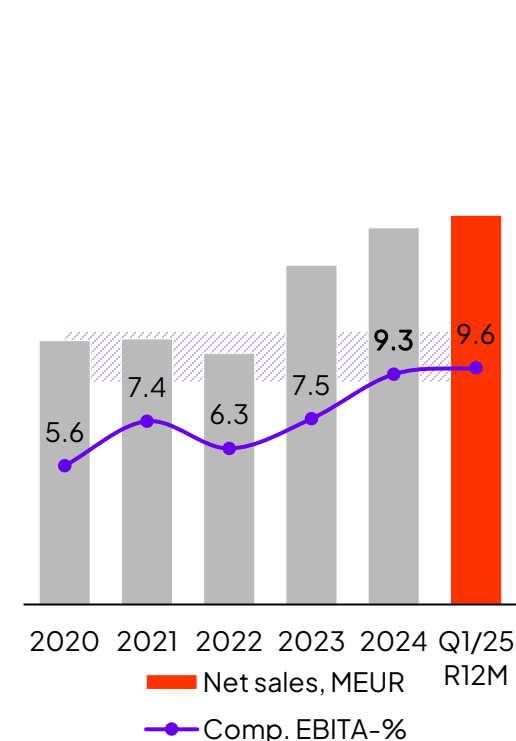

Note (1): Profitability range, depending on the cycle

Demand outlook

Within industrial customer segments:

Americas

EMEA

Asia-Pacific

Our demand environment within industrial customer segments has remained good and continues on a healthy level. That said, the demand-related uncertainty and volatility due to the geopolitical and trade policy tensions have increased compared to the previous quarters.

Within port customers:

Global container throughput continues on a high level, and long-term prospects related to global container handling remain good overall.

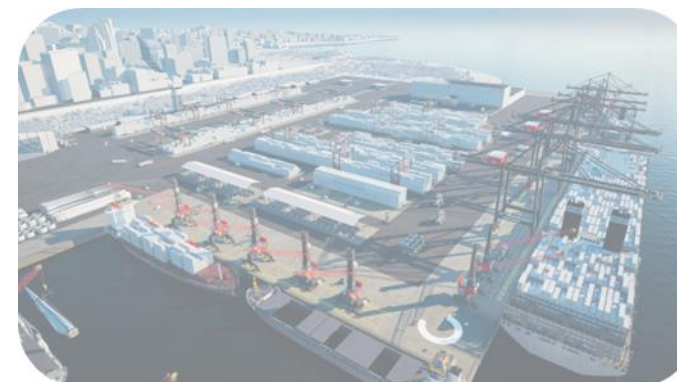



Financial guidance for 2025

Net sales expected to remain approximately on the same level in 2025 compared to 2024.

Comparable EBITA margin expected to remain approximately on the same level or to improve in 2025 compared to 2024.

Agenda



Anders Svensson
President and CEO

1. Quarter's highlights p. 4
2. Market environment p. 5
3. Group financial performance p. 7
4. Demand outlook & financial guidance p. 11



Teo Ottola
CFO

- 5. Group profitability bridge p. 14**
6. Business Areas p. 15
7. Net working capital & free cash flow p. 18
8. Gearing & return on capital employed p. 19

Q&A

Q1 2025 comparable EBITA bridge

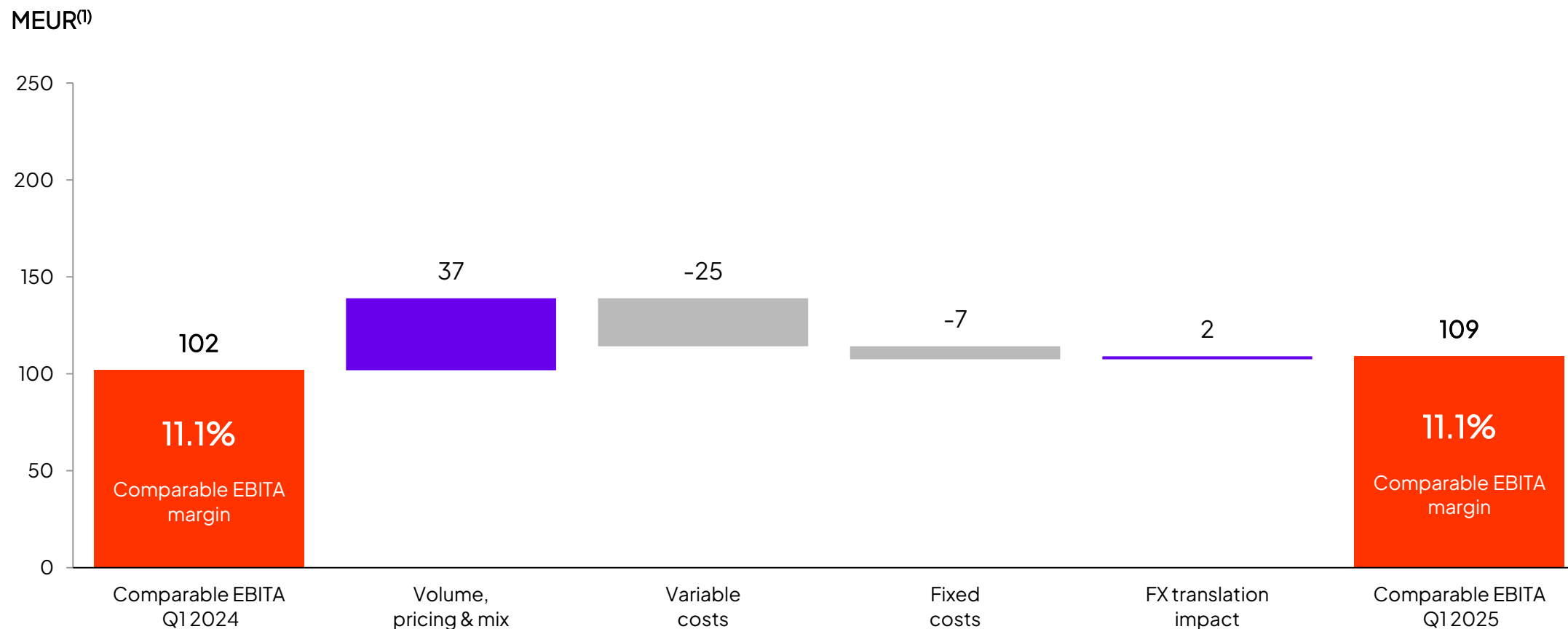

Note (1): Volume, pricing & mix, Variable costs, and Fixed costs effects do not include the FX translation impact component

Industrial Service

Order intake and net sales, MEUR⁽¹⁾

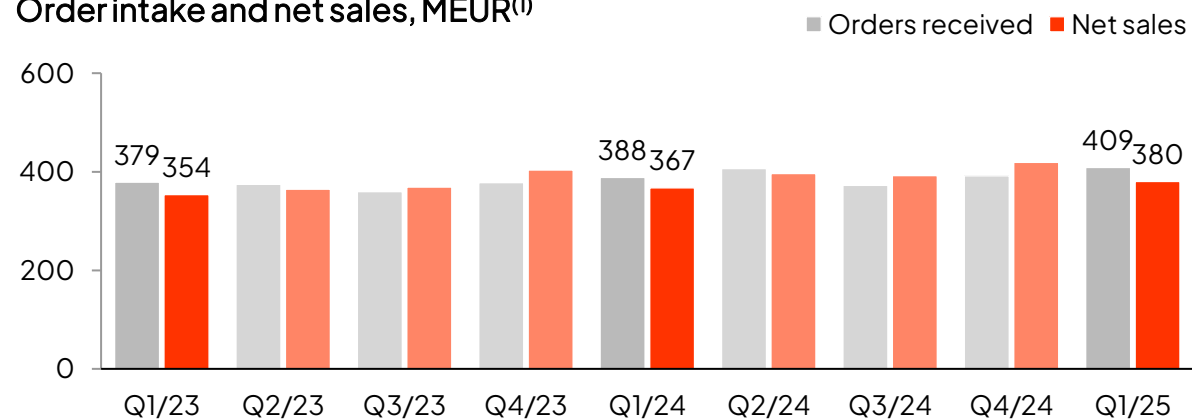

Comp. EBITA, MEUR & margin-%

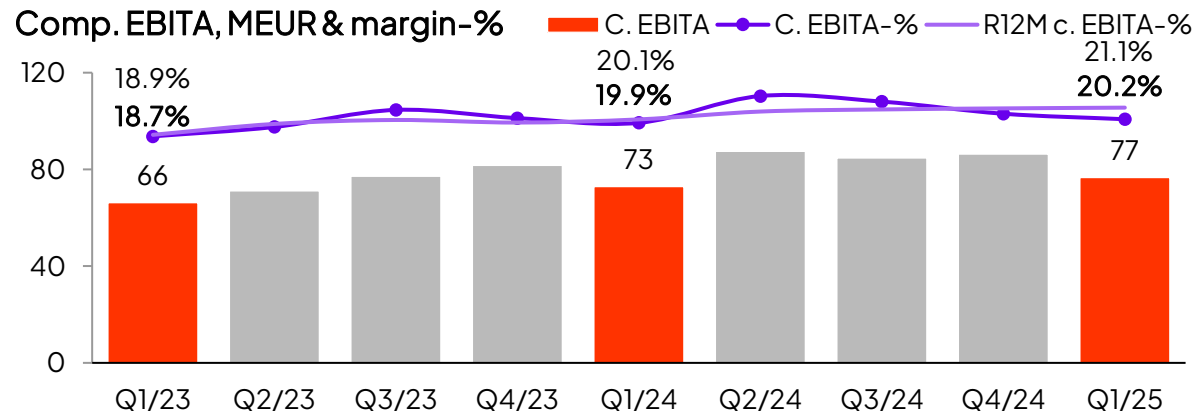

Order intake

+5.2%
Y/Y reported

+4.2%
Y/Y comp. FX

- Increase in field service and parts
- Increase in the Americas and EMEA, decrease in APAC

Agreement base:

- EUR 340.3 million, +4.4% Y/Y
- +4.9% Y/Y comp. FX

Net sales

+3.6%
Y/Y reported

+2.5%
Y/Y comp. FX

- Increase in parts, approx. on the same level in field service
- Increase in EMEA and APAC, decrease in the Americas

Orderbook:

- EUR 449.8 million, -3.5% Y/Y

Comp. EBITA

20.2%
margin

+0.3 pp
Y/Y

- Comparable EBITA-% increase mainly attributable to pricing
- Gross margin increased

Note (1): Agreement base included in orders received from Q1 2023 onwards and historical figures are restated

Industrial Equipment

Order intake and net sales, MEUR⁽¹⁾

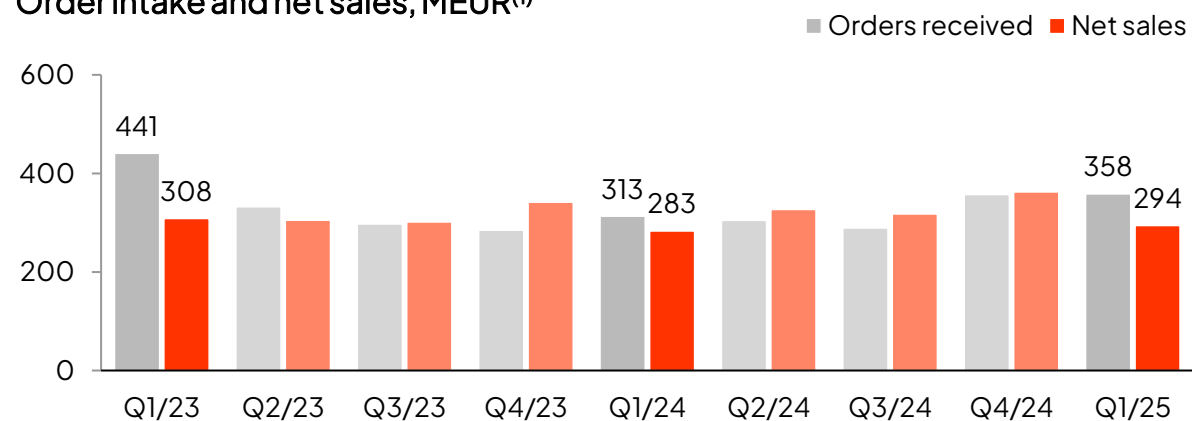

Comp. EBITA, MEUR & margin-%

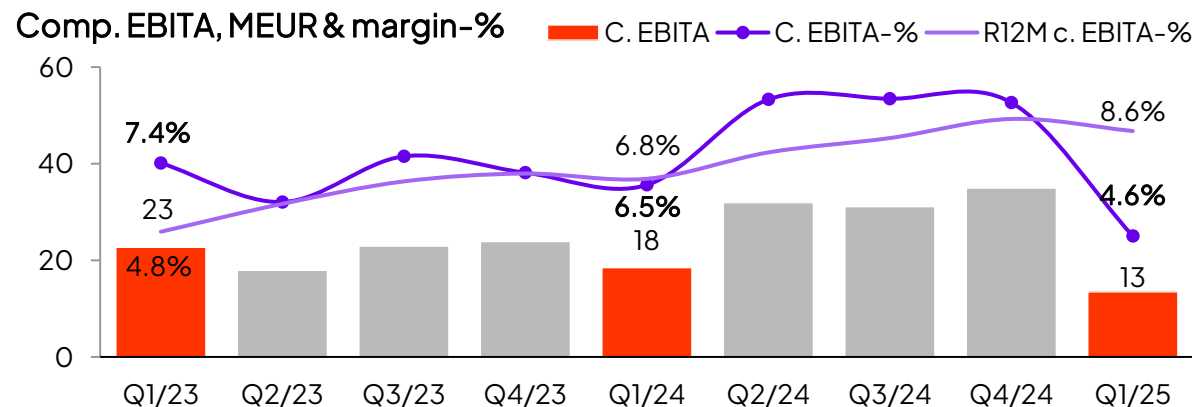

Order intake

+14.4%
Y/Y reported
+13.5%
Y/Y comp. FX

- External orders +13.5% Y/Y comp. FX
- Increase in standard cranes and process cranes, decrease in components
- Increase in EMEA and in the Americas, decrease in APAC

Net sales

+3.7%
Y/Y reported
+2.9%
Y/Y comp. FX

- External sales +3.5% Y/Y comp. FX
- Increase in standard cranes and process cranes, approx. on the same level in components
- Increase in the Americas and EMEA, decrease in APAC

Orderbook: EUR 939.9 million, +0.8% Y/Y

Comp. EBITA

4.6%
margin
-1.9 pp
Y/Y

- Comparable EBITA-% decrease mainly attributable to lower productivity and weaker mix
- Gross margin decreased

Note (1): Agreement base included in orders received from Q1 2023 onwards and historical figures are restated

Port Solutions

Order intake and net sales, MEUR⁽¹⁾

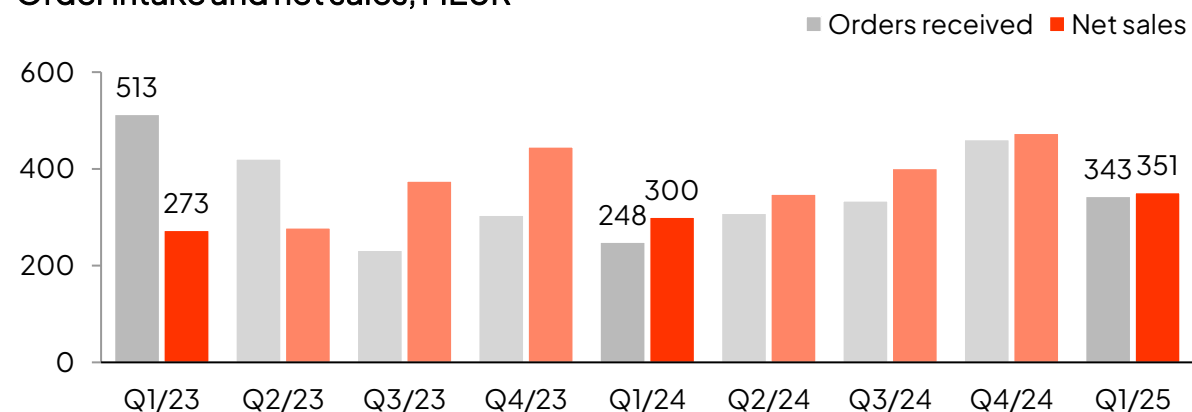

Comp. EBITA, MEUR & margin-%

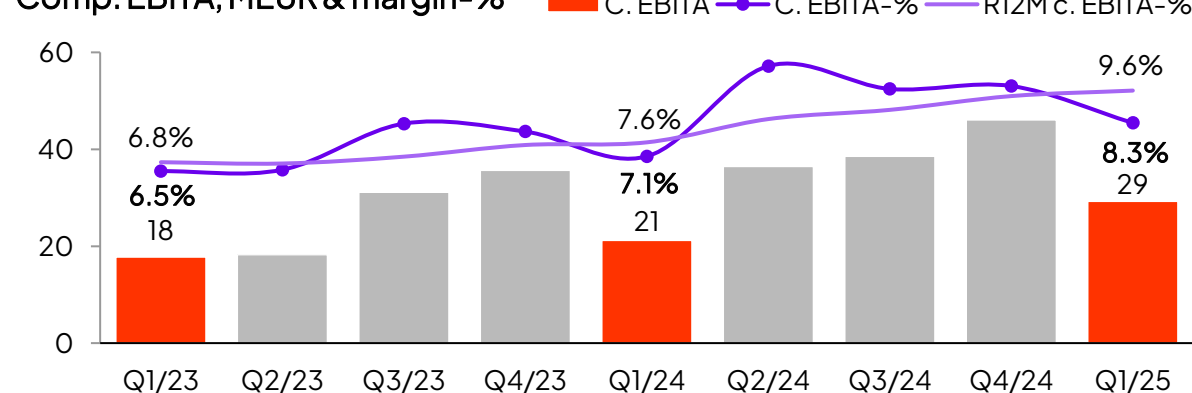

Note (1): Agreement base included in orders received from Q1 2023 onwards and historical figures are restated

Order intake

+38.2%
Y/Y reported
+37.5%
Y/Y comp. FX

- Increase in the Americas and EMEA, decrease in APAC
- Good order intake in Mobile Harbor Cranes, Rubber-Tired Gantry Cranes, Automated Guided Vehicles and Port Services

Net sales

+17.1%
Y/Y reported
+16.5%
Y/Y comp. FX

Orderbook:

- EUR 1,552.1 million, -5.8% Y/Y

Comp. EBITA

8.3%
margin
+1.3 pp
Y/Y

- Comparable EBITA-% increase mainly attributable to volume growth and pricing
- Gross margin stayed approximately on the same level

Net working capital and free cash flow

Net working capital, MEUR and percentage of sales⁽¹⁾⁽²⁾

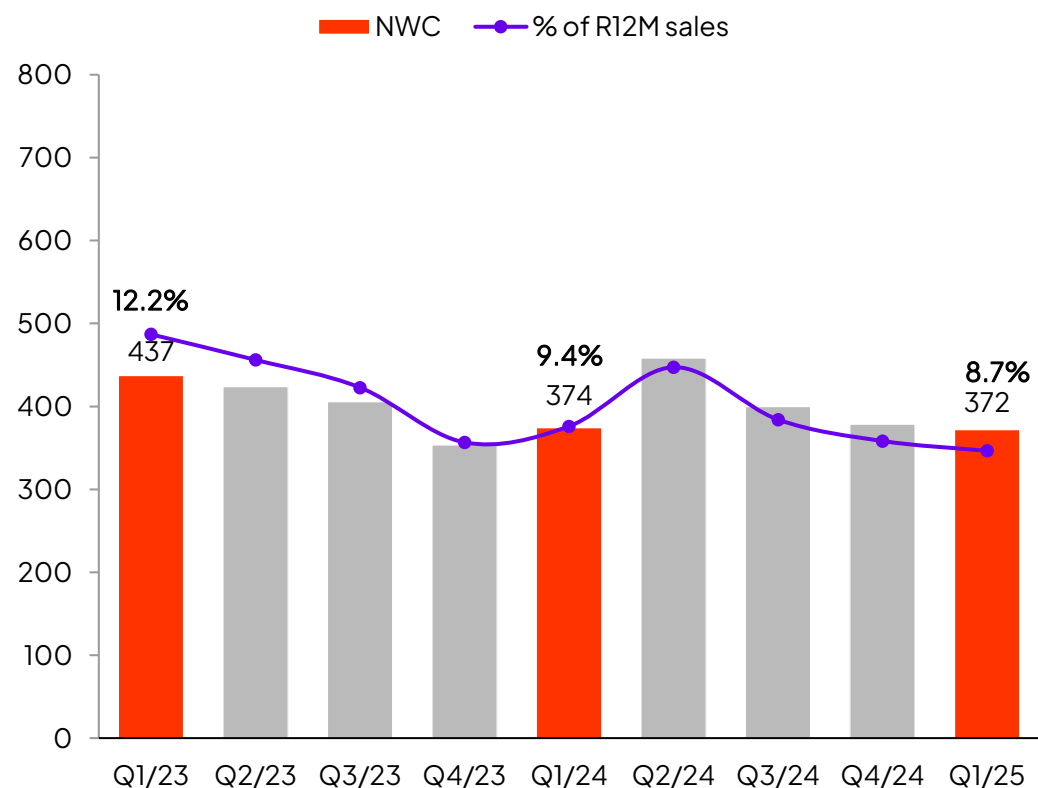

Free cash flow, MEUR

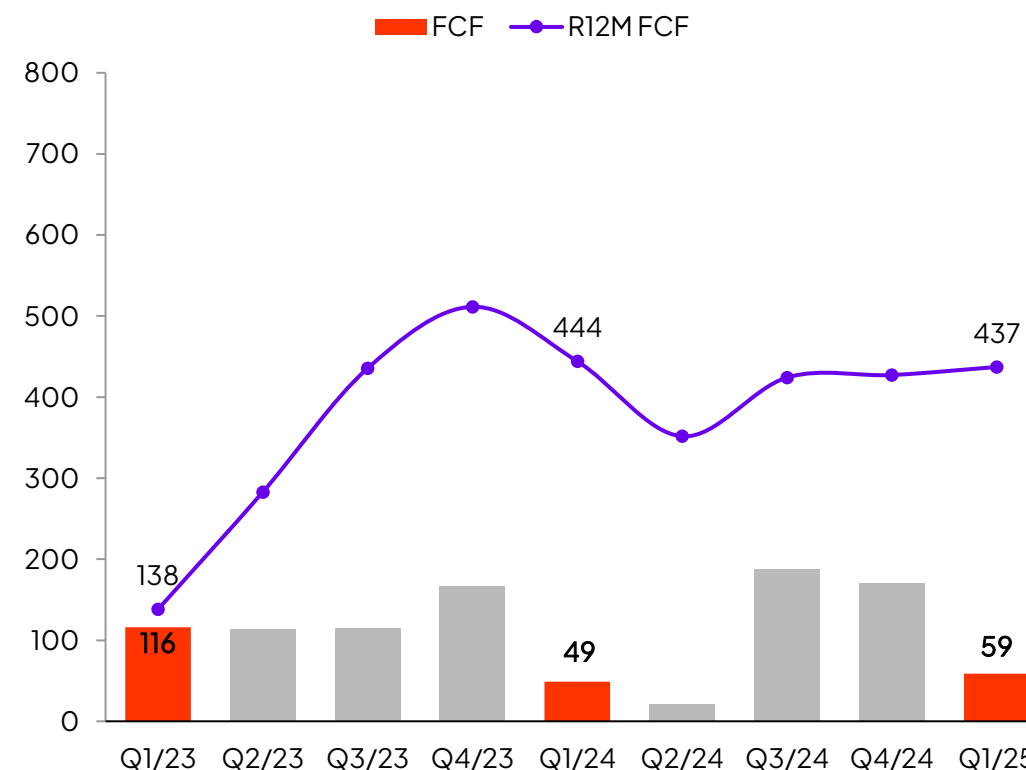

Note (1): NWC formula changed from Q1 2023 onwards and historical figures are restated
 Note (2): Q1/25 excluding dividend payable of EUR 130.7 million, Q1/24 excluding dividend payable of EUR 106.9 million

Gearing and return on capital employed

Equity & net debt, MEUR and gearing, %

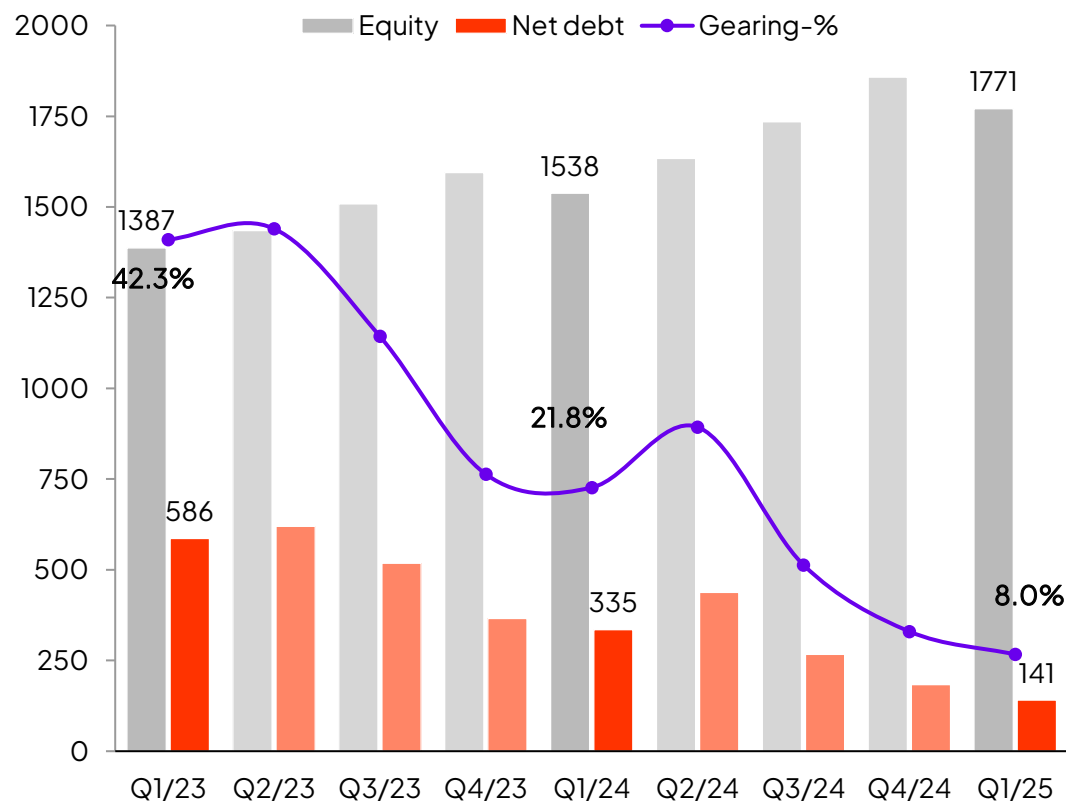

Capital employed, MEUR and comp. return on capital employed, %

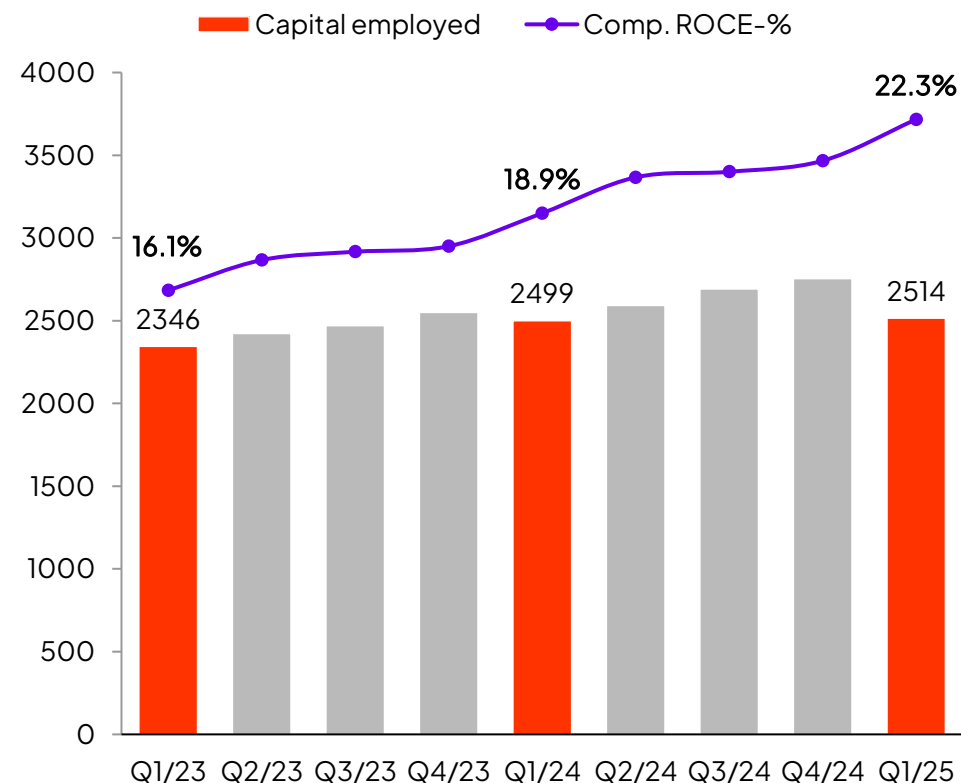

Konecranes' exposure to US tariffs

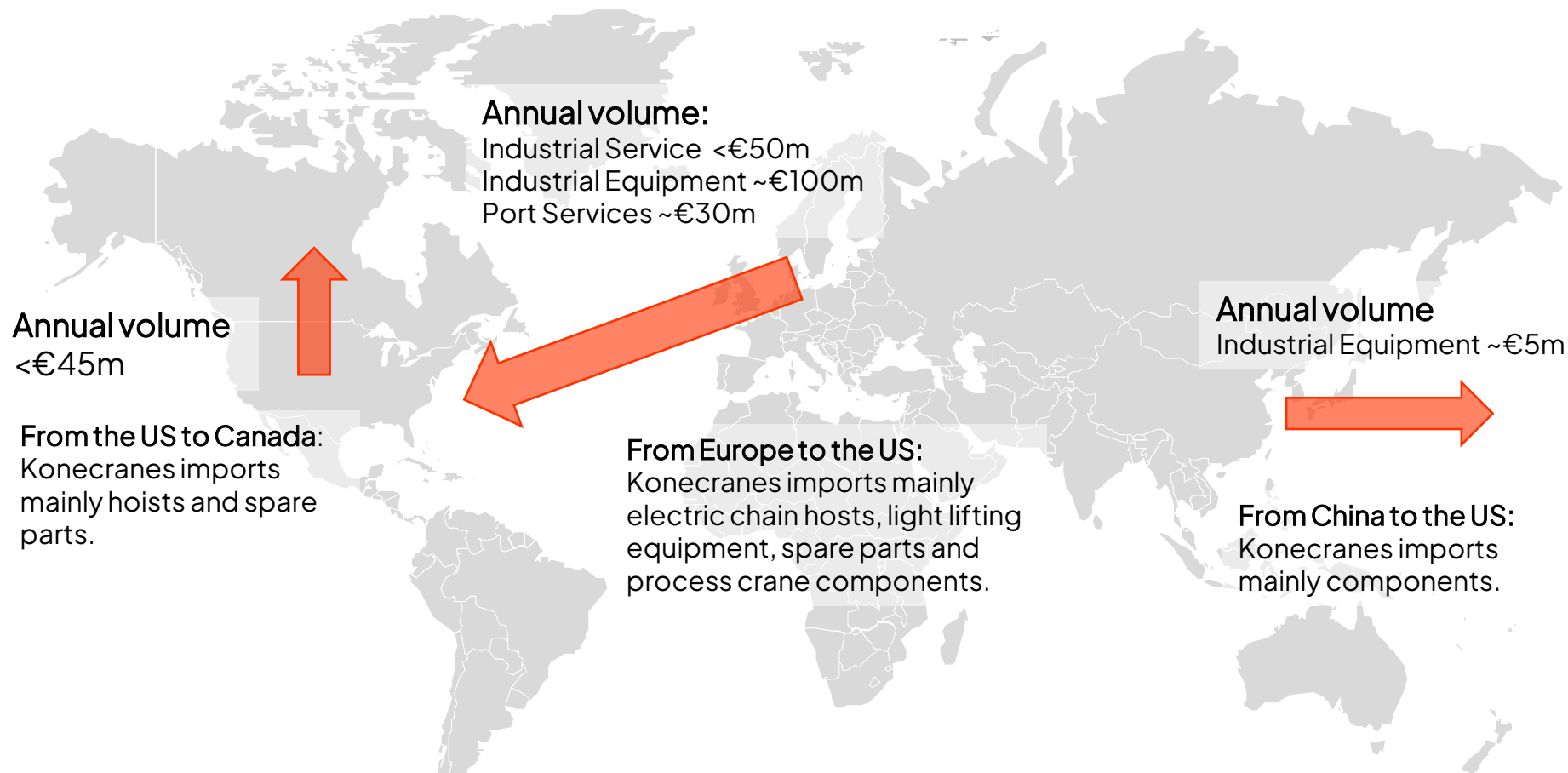

Actions taken:

- Price increases applied to all parts imported from Europe
- Price increases also applied to light lifting equipment and components
- Tariff clauses in offers and contracts
- Demand and price increase acceptance closely monitored
- Dynamic tariff tracking process in place

Port Solutions: Konecranes mainly ships fully assembled port cranes and lift trucks. According to current offers and contracts, customers are mainly responsible for tariff costs.

KONECRANES

40.0 t

Q&A



0.4

0.45

0.5

0.57

0.6

0.9

0.89

0.8

0.45

0.94

Appendix

Group R12M sales split

Group R12M sales by Business Area

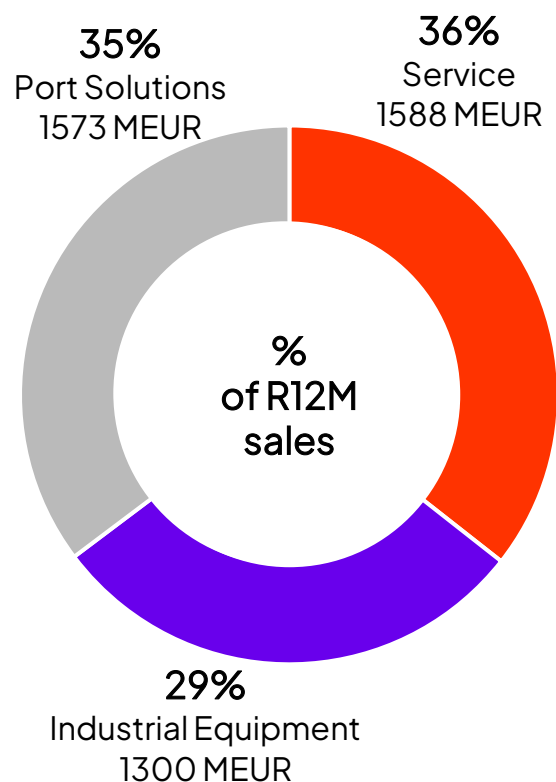

Group R12M sales by offering type⁽¹⁾

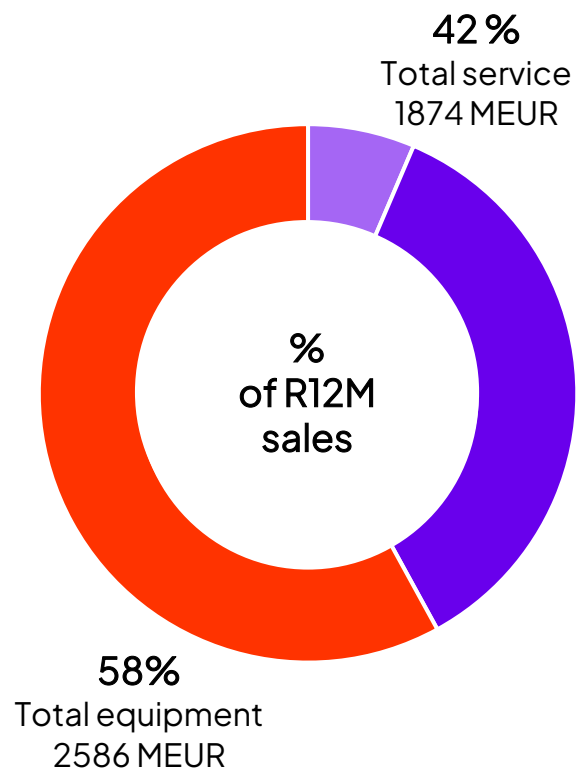

Group R12M sales by region

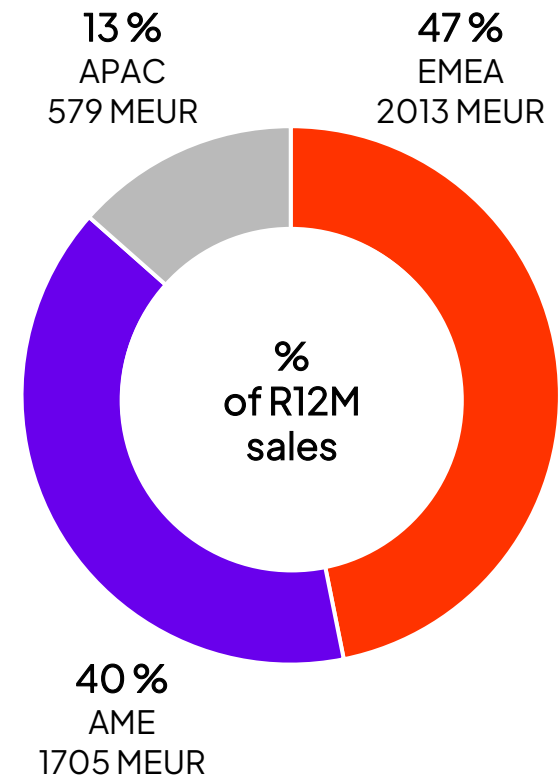

Note (1): Total service includes Service and Port Solutions' service sales, Total equipment includes Industrial Equipment and Port Solutions excluding Port Solutions' service sales

Service agreement base and order book by Business Area

Service agr. base & order book, MEUR

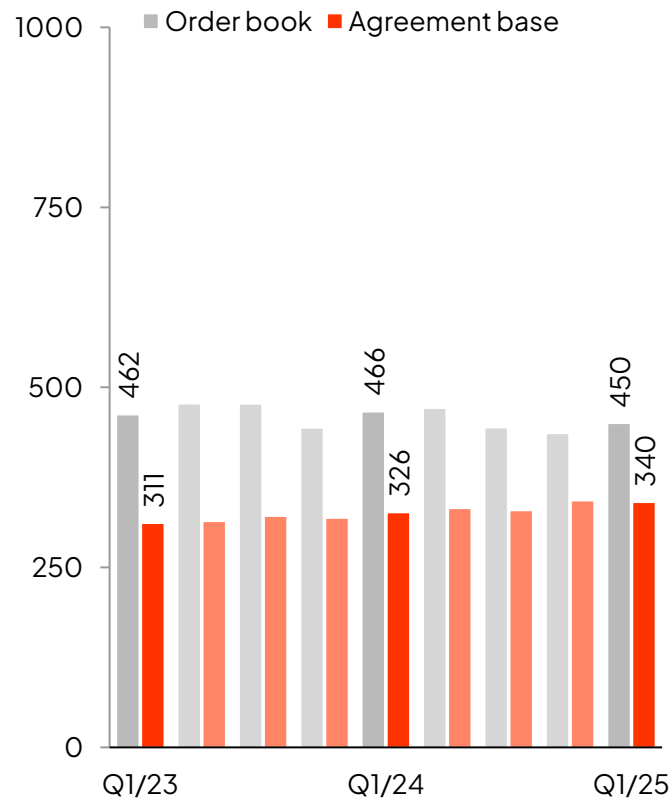

Industrial Equipment order book, MEUR

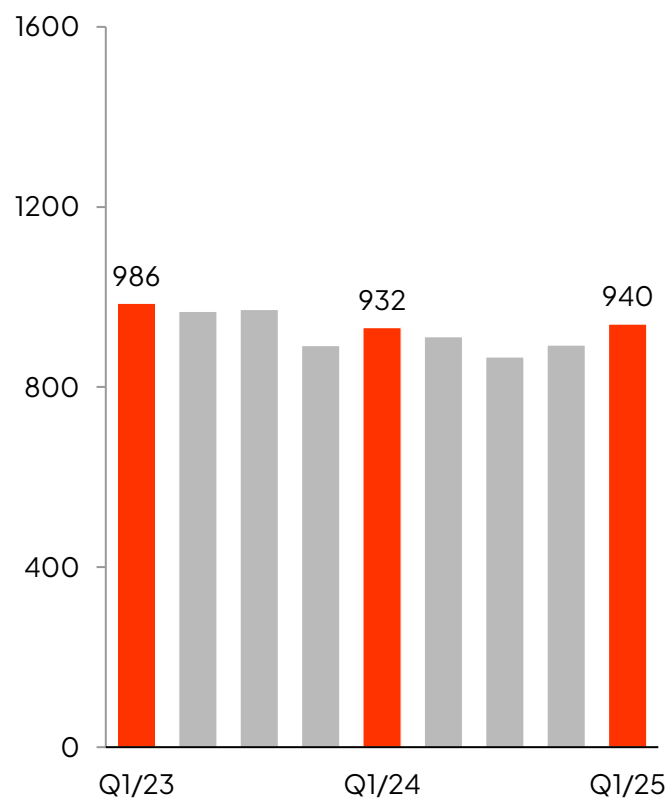

Port Solutions order book, MEUR

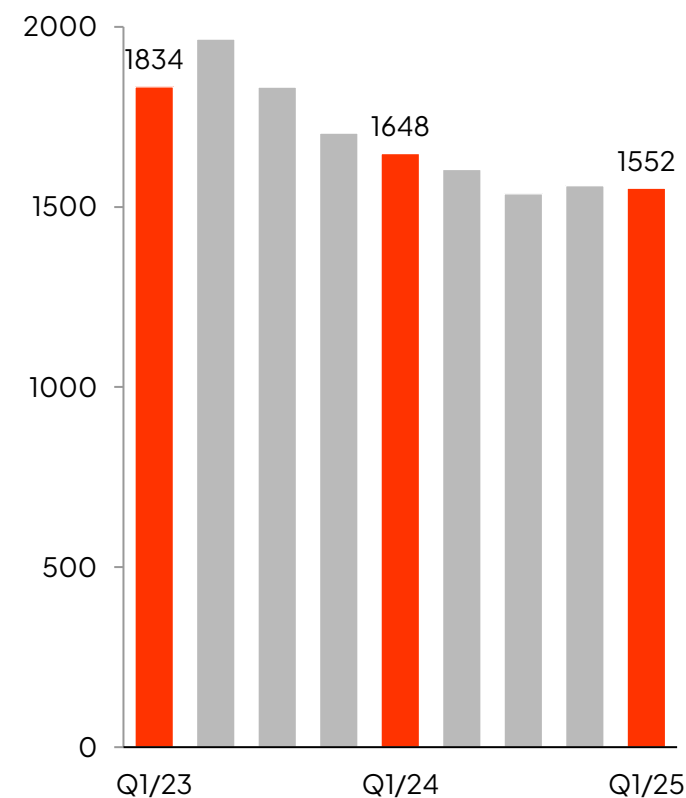

Group key figures 1/2

EUR million	1-3/ 2025	1-3/ 2024	Change %	Change % Comp. FX	1-12/ 2024
Orders received, MEUR	1,062.2	909.1	16.8	15.9	3,999.6
Order book at end of period, MEUR	2,941.8	3,046.4			2,888.4
Sales total, MEUR	983.7	913.1	7.7	6.9	4,227.0
Comparable EBITDA, MEUR	136.1	124.4	9.4		641.7
Comparable EBITDA, %	13.8%	13.6%			15.2%
Comparable EBITA, MEUR	109.0	101.8	7.1		551.6
Comparable EBITA, %	11.1%	11.1%			13.1%
Operating profit (EBIT), MEUR	100.0	89.1	12.2		511.4
Operating margin (EBIT), %	10.2%	9.8%			12.1%
Net profit for the period, MEUR	73.5	59.3	24.0		368.4
Earnings per share, basic (EUR)	0.93	0.75	24.0		4.65
Earnings per share, diluted (EUR)	0.93	0.75	24.1		4.63
Free cash flow, MEUR	58.7	48.8			427.2
Gearing, %	8.0	21.8			9.9%
Comparable ROCE, %. (R12M)	22.3	18.9			20.8%

Group key figures 2/2

EUR million	1-3/ 2025	1-3/ 2024	Change %	1-12/ 2024
ROCE, %, (R12M)	22.1	17.6	25.6	20.3
Return on equity, %, (R12M)	23.1	19.3	19.7	21.3
Equity per share (EUR)	22.36	19.41	15.2	23.45
Net debt / Comparable EBITDA, (R12M)	0.2	0.6	-66.7	0.3
Equity to asset ratio, %	44.4	39.5	12.4	44.4
Investments total (excl. acquisitions), MEUR	15.7	11.5	36.5	65.7
Interest-bearing net debt, MEUR	140.9	334.7	-57.9	183.5
Net working capital, MEUR	241.5	267.2	-9.6	378.6
Average number of personnel during the period	16,766	16,570	1.2	16,656
Average number of shares outstanding, basic	79,214,155	79,208,967	0.0	79,209,080
Average number of shares outstanding, diluted	79,301,675	79,406,550	-0.1	79,488,202
Number of shares outstanding	79,214,269	79,209,118	0.0	79,209,118

Key figures by Business Area

EUR million	1-3/ 2025	1-3/ 2024	Change %	Change % Comp. FX	1-12/ 2024
Industrial Service					
Orders received, MEUR	408.7	388.5	5.2	4.2	1,559.0
Agreement base value, MEUR	340.3	326.0	4.4	4.9	342.5
Sales, MEUR	380.4	367.2	3.6	2.5	1,574.7
Comparable EBITA, MEUR	76.6	72.9	5.1		331.5
Comparable EBITA, %	20.2%	19.9%			21.0%
Industrial Equipment					
Orders received, MEUR	358.2	313.0	14.4	13.5	1,263.5
of which external	330.9	289.2	14.4	13.5	1,165.6
Sales, MEUR	293.7	283.1	3.7	2.9	1,289.3
of which external	273.3	261.9	4.4	3.5	1,205.5
Comparable EBITA, MEUR	13.5	18.5	-27.1		116.5
Comparable EBITA, %	4.6%	6.5%			9.0%
Port Solutions					
Orders received, MEUR	343.0	248.3	38.2	37.5	1,350.5
Sales, MEUR	351.0	299.9	17.1	16.5	1,521.7
Comparable EBITA, MEUR	29.2	21.2	38.0		142.2
Comparable EBITA, %	8.3%	7.1%			9.3%

Statement of income

EUR million	1-3/ 2025	1-3/ 2024	Change%	1-12/ 2024
Sales	983.7	913.1	7.7	4,227.0
Other operating income	2.4	4.6		10.5
Materials, supplies and subcontracting	-398.6	-359.8		-1,878.2
Personnel cost	-337.2	-328.0		-1,264.0
Depreciation and impairments	-35.7	-30.3		-120.5
Other operating expenses	-114.6	-110.5		-463.4
Operating profit	100.0	89.1	12.2	511.4
Share of associates' and joint ventures' result	-0.1	0.0		0.6
Financial income	13.6	7.5		31.2
Financial expenses	-15.8	-17.0		-57.9
Profit before taxes	97.7	79.5	23.0	485.3
Taxes	-24.2	-20.2		-116.9
Profit for the period	73.5	59.3	24.0	368.4

Balance sheet

EUR million	31 Mar 2025	31 Mar 2024
Non-current assets	2,049.7	1,998.7
Goodwill	1,053.2	1,040.1
Intangible assets	441.6	454.7
Property, plant and equipment	431.5	361.6
Other	123.4	142.3
Current assets	2,550.9	2,599.9
Inventories	930.4	1,046.7
Accounts receivable	563.2	538.1
Receivables and other current assets	458.8	391.3
Cash and cash equivalents	598.5	623.8
Assets held for sale	0.0	0.0
Total Assets	4,600.5	4,598.5

EUR million	31 Mar 2025	31 Mar 2024
Total Equity	1,771.0	1,537.7
Non-current liabilities	882.2	1,111.3
Interest-bearing liabilities	478.3	731.0
Other long-term liabilities	228.0	231.1
Other	175.8	149.2
Current liabilities	1,947.3	1,949.6
Interest-bearing liabilities	265.0	229.9
Advance payments received	613.4	702.7
Accounts payable	312.5	316.6
Provisions	98.5	96.9
Other current liabilities	657.9	603.4
Liabilities directly attributable to assets held for sale	0.0	0.0
Total Equity and Liabilities	4,600.5	4,598.5

Cash flow statement

EUR million	1-3/ 2025	1-3/ 2024	1-12/ 2024
Operating income before change in net working capital	117.2	113.8	631.4
Change in net working capital	-18.8	-18.4	-5.3
Cash flow from operations before financing items and taxes	98.4	95.4	626.1
Financing items and taxes	-30.4	-33.7	-134.5
Net cash from operating activities	68.1	61.7	491.6
Net cash used in investing activities	-9.4	-12.9	-111.0
Cash flow before financing activities	58.7	48.8	380.6
Net cash used in financing activities	-165.5	-11.1	-256.8
Translation differences in cash	-4.7	-0.4	-0.4
Change of cash and cash equivalents	-111.5	37.3	123.4
Free cash flow	58.7	48.8	427.2

Thank you

Contact information

Kiira Fröberg
Vice President, Investor Relations
Email: kiira.froberg@konecranes.com, tel: +358 20 427 2050

Ruusa Vallin
Manager, Investor Relations
Email: ruusa1.vallin@konecranes.com, tel: +358 20 427 2961